

Maintenance BMW Integral ABS



R 1150 RT

**BMW Motorrad
After Sales**

Published by: © BMW Motorrad
After Sales
UX-VS-2

All rights reserved. Not to be reprinted, translated or duplicated either wholly or in part without prior written permission.
Errors and omissions excepted; subject to technical amendment.

Produced in Germany 01/01

BMW Motorrad

Maintenance schedule

R 1100 S EVO / R 1150 R / R 1150 RT



		BMW Inspection at 1,000 km (600 miles)	BMW Service 10,000 km (6,000 miles)	BMW Inspection every 20,000 km (12,000 miles)	BMW Annual Service
Customer	Registration No.				
Order No.	Mechanic's signature				
Read the fault code memory with the BMW MoDiTeC		<input type="checkbox"/>	<input type="checkbox"/>	<input type="checkbox"/>	<input type="checkbox"/>
[Integral ABS] perform bleed test with BMW MoDiTeC		<input type="checkbox"/>	<input type="checkbox"/>	<input type="checkbox"/>	
Change oil while at regular operating temperature and replace the oil filter element If the motorcycle is ridden only for short distances or outside temperatures are below 0 °C: at the latest every 3,000 km (1,800 miles)*		<input type="checkbox"/>	<input type="checkbox"/>	<input type="checkbox"/>	<input type="checkbox"/>
Change oil in gearbox while at operating temperature every 2 years*) at the latest				<input type="checkbox"/>	<input type="checkbox"/> every 2 years
Change oil in rear wheel drive while at operating temperature if necessary, clean inductive sensor on rear wheel every 40,000 km (24,000 miles) or at the latest every 2 years*)		<input type="checkbox"/>		<input type="checkbox"/> 40,000	<input type="checkbox"/> every 2 years
Replace fuel filter *) Normally every 40,000 km (24,000 miles), if fuel is of poor quality every 20,000 km (12,000 miles)				<input type="checkbox"/> 40,000	
Check the battery fluid level, if necessary top up with distilled water Clean and grease battery poles if necessary				<input type="checkbox"/>	<input type="checkbox"/>
Replace intake air filter element In very dirty and dusty operating conditions, replace every 10,000 km (6,000 miles) or even more frequently if necessary *)				<input type="checkbox"/>	
Replace Poly-V belt *) Replace the Poly-V belt every 60,000 km (36,000 miles); do not adjust it				<input type="checkbox"/> 60,000	
Check brake fluid level at front and rear			<input type="checkbox"/>	<input type="checkbox"/>	
Check operation of brake system and freedom from leaks; repair/replace items if necessary*)				<input type="checkbox"/>	
Examine brake pads and discs for wear, replace as necessary*)			<input type="checkbox"/>	<input type="checkbox"/>	
[Without ABS] change brake fluid every twelve months					<input type="checkbox"/>
[Integral ABS] change brake fluid in wheel circuit every 12 months					<input type="checkbox"/>
[Integral ABS] change brake fluid in control circuit every 2 years*)					<input type="checkbox"/> every 2 years
[Integral ABS] perform bleed test with BMW MoDiTeC					<input type="checkbox"/>
Check clutch fluid level			<input type="checkbox"/>	<input type="checkbox"/>	
Change the clutch fluid*) every 2 years at the latest					<input type="checkbox"/> every 2 years
Check tightness of rear wheel studs		<input type="checkbox"/>			
Check rear wheel bearing play by tilting wheel				<input type="checkbox"/>	
Check swinging arm bearings (freedom from play), adjust if necessary *)		<input type="checkbox"/>		<input type="checkbox"/>	
Grease the side stand pivot		<input type="checkbox"/>	<input type="checkbox"/>	<input type="checkbox"/>	
Check function of side stand contact switch		<input type="checkbox"/>	<input type="checkbox"/>	<input type="checkbox"/>	<input type="checkbox"/>
Check condition of spark plugs			<input type="checkbox"/>		
Replace spark plugs				<input type="checkbox"/>	
Tighten cylinder head nuts		<input type="checkbox"/>			
Check/adjust valve clearances		<input type="checkbox"/>	<input type="checkbox"/>	<input type="checkbox"/>	
Check that the throttle cable moves freely and is free of kinks and chaffing, replace if necessary *) Check throttle-cable play check synchronisation, repair leaks if necessary *)		<input type="checkbox"/>	<input type="checkbox"/>	<input type="checkbox"/>	
Final inspection with road safety and functional check: – Condition of tyres and wheels, tyre pressures – Lights and signalling equipment, telltale and warning lights, instruments, – clutch, gearshift mechanism, hand brake and foot brake, steering, – if necessary, test drive		<input type="checkbox"/>	<input type="checkbox"/>	<input type="checkbox"/>	<input type="checkbox"/>
*) Charged as an additional item					

BMW Motorrad

Pre-delivery check

R 1100 S EVO / R 1150 R / R 1150 RT



<p>_____</p> <p>Customer</p> <p>_____</p> <p>Order No.</p>	<p>_____</p> <p>Registration No.</p> <p>_____</p> <p>Mechanic's signature</p>	<p>BMW Pre-delivery check</p>
<p>Check the shipping crate for damage</p>		
<p>Motorcycle:</p> <ul style="list-style-type: none"> - unpack - install remaining items - inspect for damage - check that delivery is complete: Toolkit On-board literature Ignition keys Scope of optional extras 		<p><input type="checkbox"/></p>
<p>Fill and charge the battery (mark with charging date)</p>		<p><input type="checkbox"/></p>
<p>Check engine oil level when cold and correct if necessary.</p>		<p><input type="checkbox"/></p>
<p>Check headlight setting and adjust if necessary.</p>		<p><input type="checkbox"/></p>
<p>Check tightness of rear wheel studs (note correct tightening torque)</p>		<p><input type="checkbox"/></p>
<p>Check tyre pressures</p>		<p><input type="checkbox"/></p>
<p>Fill up with fuel</p>		<p><input type="checkbox"/></p>
<p>[Integral ABS] perform bleed test with BMW MoDiTeC</p>		<p><input type="checkbox"/></p>
<p>Final inspection as functional check:</p> <ul style="list-style-type: none"> - Clutch, gear shift - Handbrake and foot brake - Lights and signalling equipment, telltale and warning lights, instruments, - Check operation of optional extras - If necessary, test drive 		<p><input type="checkbox"/></p>
<p>Confirm pre-delivery check in "Service and Technical Booklet".</p>		<p><input type="checkbox"/></p>
<p>Final cleaning</p>		<p><input type="checkbox"/></p>
<p>Motorcycle handed over on:</p>		

BMW Motorrad

Service data

R 1150 RT



Item	Desired value	Unit of measurement/specification
Oil capacities		
Engine (with filter) (without filter)	3.75 (6.6) 3.50 (6.15)	litres (Imp. pints) litres (Imp. pints) [SI 11 048 90] Engine oil grade: brand-name HD oil for four-stroke spark-ignition engines, API classes SE, SF, SG; combination with CC or CD specification
Transmission Initial filling Oil changes	approx. 1.0 (1.76) approx. 0.8 (1.41) of oil to bottom edge of filler neck	litres (Imp. pints) litres (Imp. pints) Brand-name hypoid gear oil, SAE class GL 5 SAE 90
Rear wheel drive Initial filling/oil change	approx. 0.25 (0.44) of oil to bottom edge of filler neck	litres (Imp. pints) Brand-name hypoid gear oil, SAE class GL 5 SAE 90
Valve clearances measured cold (max. 35 °C/95 °F)		
	Inlet: 0.15 (0.006) Exhaust: 0.30 (0.012)	mm (in) mm (in)
Ignition timing static setting		
	adjust at TDC	
Spark plugs		
Electrode gap	0.8 (0.0315)	mm (in)
Wear limit	1.0 (0.039)	mm (in)
Idle speed		
	1,100 ±50	rpm
Throttle cable setting for cold-start (increased idle) speed for throttle (twistgrip) cable for divider cable		
	zero play approx. 0.5 (0.02) zero play	mm (in) free travel
Brakes		
Colour of identification mark on brake calipers/brake pads, front	white	DOT 4 brake fluid
Minimum front pad thickness	1.0 (0.039)	mm (in)
Minimum rear pad thickness	1.0 (0.039) (wear mark)	mm (in)
Minimum front disc thickness	4.5 (0.177)	mm (in)
Minimum rear disc thickness	4.5 (0.177)	mm (in)
Tyre pressures depending on load		
	front: 2.2 – 2.5 (31.9 – 36.26) rear: 2.5 – 2.9 (36.26 – 42.06)	bar (psi) bar (psi)
Tightening torques:		
Oil filter	11	Nm
Engine oil drain plug	32	Nm
Gearbox oil filler plug	30	Nm
Gearbox oil drain plug	30	Nm
Rear wheel drive oil filler/drain plug	23	Nm
Fuel tank to rear frame	22	Nm
Fuel pump assembly to tank	5	Nm
Poly-V belt preload	8	Nm
Alternator to cover mount	20	Nm
Brake caliper fasteners, front	30	Nm
Brake caliper fasteners, rear	40	Nm
Rear wheel studs	105	Nm
Tightening cylinder heads		
Nut	unscrew/20 180	Nm ° tightening angle
M 10 screw	unscrew/40	Nm
Locknut, valve adjusting screw	8	Nm
Cylinder head cover	8	Nm
Spark plugs NGK BKR 7 EKC	25	Nm

00 Tightening torque

Table of operating fluids

Contents

Page

Tightening torque	3
11 Engine	3
12 Engine electrics	5
13 Fuel preparation and control	5
16 Fuel tank and lines	5
18 Exhaust system	5
21 Clutch	6
23 Transmission	6
31 Front forks	7
32 Steering	7
33 Rear wheel drive	8
34 Brakes	9
36 Wheels and tyres	9
46 Frame	10
51 Equipment	11
61 General electrical equipment	11
Table of operating fluids	12





Tightening torque

Model	R 1150 RT	
Connection		
11 Engine		
Cylinder head		
Tightening sequence:		
1 Tighten cylinder head nuts (oiled) in diagonally opposite sequence		
1.1 Tighten all nuts to closing torque	Nm	20
1.2 Tighten all nuts to correct wrench angle	°	90
1.3 Tighten all nuts to correct wrench angle	°	90
2 M 10 screw	Nm	40
3 M 6 screw	Nm	9
After 1,000 km (600 miles), tighten cylinder head nuts in diagonally opposite sequence:		
1 Slacken one nut		
2 Tighten nut to initial torque	Nm	20
3 Tighten nut to wrench angle	°	180
4 Slacken and retighten M 10 screw	Nm	40
Timing gear carrier to cylinder head	Nm	9
Bearing cap on rocker shaft	Nm	18
Locknut, valve adjusting screw	Nm	8
Cylinder head cover to cylinder head	Nm	8
Camshaft end cover to cylinder head	Nm	9
Air intake connection to cylinder head	Nm	9
Camshaft		
Chain sprocket to camshaft	Nm	65
Camshaft bearing cap	Nm	15
Alternator mount cover		
M 6 screw	Nm	9
M 8 screw	Nm	20
Auxiliary shaft		
Chain sprocket to crankshaft	Nm	10
Chainwheel to auxiliary shaft	Nm	70
Chain tensioner housing to engine block	Nm	9

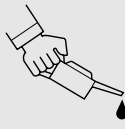



Model		R 1150 RT
Connection		
11 Engine		
Oil filter		
Oil filter	Nm	11
Oil drain plug	Nm	32
Oil pump		
Mesh filter basket to engine block	Nm	10
Oil pump cover	Nm	9
Pressure relief valve	Nm	42
Oil pressure switch	Nm	30
Oil cooler		
Cooling oil line to engine block	Nm	10
Cooling oil line banjo screw with oil vent valve	Nm	25
Oil cooler to bracket	Nm	9
Oil cooler return line to engine block	Nm	35
Oil cooler connection to crankcase	Nm	9
Cylinders		
Tightening sequence:		
1 M 8 screw	Nm	20
2 M 6 screw	Nm	9
3 Chain guide rail pivot screw	Nm	18
Timing chain		
Chain tensioner	Nm	32
Connecting rod		
Big end cap		
Closing torque	Nm	20
Wrench angle	°	80
Crankcase		
Tightening sequence:		
M 10 screw (oiled) to initial torque	Nm	25
Wrench angle	°	90
M 8 screw	Nm	22 (oiled)
M 6 screw	Nm	9

Model	R 1150 RT	
Connection		
12 Engine electrics		
Starter motor to engine	Nm	20
Positive lead to starter motor	Nm	10
Alternator to generator support cover	Nm	20
Tensioning and retaining link to alternator	Nm	21
Spacer to alternator	Nm	21
Positive lead to alternator	Nm	15
Belt pulley to alternator	Nm	50
Belt pulley to crankshaft	Nm	50
Poly-V belt preload	Nm	8
NGK BKR 7 EKC spark plug	Nm	25
Model	R 1150 RT	
Connection		
13 Fuel preparation and control		
Oil temperature sensor to crankcase	Nm	25
Air temperature sensor to air-filter housing	Nm	10
Model	R 1150 RT	
Connection		
16 Fuel tank and lines		
Fuel tank to rear frame	Nm	22
Fuel pump assembly to tank	Nm	5
Model	R 1150 RT	
Connection		
18 Exhaust system		
Manifold to cylinder head	Nm	21
Clamp for manifold	Nm	45 (apply Optimoly TA to clamp seat)
Silencer to footrest plate	Nm	35
Oxygen sensor to silencer	Nm	45 (apply Optimoly TA to thread)

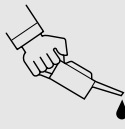



Model		R 1150 RT
Connection		
21 Clutch		
Clutch housing		
Initial tightening torque	Nm	40 (oil screw threads lightly)
+ additional wrench angle	°	32
Housing cover to housing	Nm	12
Clutch line to handlebar fitting	Nm	14
Slave cylinder to gearbox	Nm	9
Grub screw in filler adapter	Nm	10
Model		R 1150 RT
Connection		
23 Transmission		
Oil drain plug	Nm	30
Oil filler plug	Nm	30
Gearbox to engine block	Nm	22
Shift lever to footrest plate	Nm	35
Selector lever to selector shaft	Nm	9
Housing cover to housing	Nm	9
Frame tube to gearbox		
1. to gearbox and left footrest plate	Nm	42 (clean thread + Loctite 243)
2. terminal block, frame tube to transmission	Nm	9
3. to gearbox and right footrest plate	Nm	42 (clean thread + Loctite 243)

Model		R 1150 RT
Connection		
31 Front forks		
Quick-release axle clamp screws	Nm	22
Sliding tube bridge to slider tube	Nm	25 (clean thread + Loctite 243)
Threaded connection, fork fixed tube to fork bridge	Nm	45 (free from oil and grease)
Threaded stud to frame	Nm	130 (clean thread + Loctite 243)
Ball joint to sliding tube bridge	Nm	230 (lightly grease threads with Optimoly TA)
Leading link		
Leading link to ball joint		
Initial tightening	Nm	80
Final tightening	Nm	130 (clean thread + Loctite 2701)
Leading link to engine		
Right		73
Left-hand screw cap		42 (lightly grease threads with Optimoly TA)
Spring strut		
Spring strut to front frame	Nm	43
Spring strut to leading link	Nm	50
Model		R 1150 RT
Connection		
32 Steering		
Handlebars to fork bridge	Nm	21
Handlebar weight to handlebars	Nm	21
Pivot screw, handlebar lever	Nm	11 (Tuflok-Blau thread-locking compound; screw can be released and tightened a number of times)

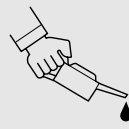



Model		R 1150 RT
Connection		
33 Rear wheel drive		
Rear axle differential		
Oil filler plug	Nm	23
Oil drain plug	Nm	23
Threaded ring	Nm	160 (clean thread + Loctite 577)
Hexagon nut, input bevel gear	Nm	200 (clean thread + Loctite 2701)
Cover to rear-wheel drive housing	Nm	35
Swinging arm		
Reaction link to rear wheel drive / gearbox	Nm	43 (load approx. 85 kg (187 lbs) onto motorcycle and tighten loose reaction link)
Fixed bearing stud bolt, Swinging arm to right rear axle housing	Nm	160 (clean thread + Loctite 2701)
Floating bearing stud bolt, Swinging arm to left rear axle housing		
1. initial torque	Nm	9
2. slacken		
3. final torque	Nm	7 (clean thread + Loctite 2701)
Lock nut, floating bearing stud bolt, Swinging arm to left rear axle housing	Nm	160
Fixed bearing stud bolt, Swinging arm to right of transmission	Nm	160 (clean thread + Loctite 2701)
Floating bearing stud bolt, Swinging arm to left of transmission		
1. initial torque	Nm	9
2. slacken		
3. final torque	Nm	7 (clean thread + Loctite 2701)
Lock nut, floating bearing stud bolt, Swinging arm to left of transmission	Nm	160
Spring strut		
Spring strut to rear frame	Nm	50
Spring strut to rear swinging arm	Nm	58 (clean thread + Loctite 243)
Hydraulic spring adjustment on rear frame	Nm	22

Model	R 1150 RT	
Connection		
34 Brakes		
Front brake		
Brake caliper to EVO brake sliding tube	Nm	30
Front brake caliper bleed screw	Nm	7
Brake disc to front wheel	Nm	21 (clean thread + Loctite 2701)
Pivot screw, handlebar lever	Nm	11 (Tuflok-Blau thread-locking compound; screw can be released and tightened a number of times)
Rear brake		
Brake caliper to rear wheel drive	Nm	40
Rear brake caliper bleed screw	Nm	5
Brake disc to rear wheel drive	Nm	21 (clean thread + Loctite 2701)
Master cylinder to footrest plate	Nm	9
Brake pedal to footrest plate	Nm	21 (clean thread + Loctite 2701)
Footbrake-lever stop	Nm	9
Brake lines		
Brake lines/brake hose to brake components	Nm	18
Brake hose to brake lever fitting	Nm	18
Filler adapter to brake line	Nm	18
Bracket to front frame	Nm	9
Retainer to rear frame	Nm	9 (clean thread + Loctite 2701)
BMW Integral ABS		
ABS pressure modulator on retainer	Nm	7
ABS pressure modulator on battery carrier	Nm	10
Model	R 1150 RT	
Connection		
36 Wheels and tyres		
Quick-release axle clamp screws	Nm	22
Quick-release axle threaded fastener	Nm	30
Rear wheel to rear wheel drive screw wheel bolts finger-tight in a cross-wise pattern	Nm	105





Model	R 1150 RT	
Connection		
46 Frame		
Frame		
Frame to engine	Nm	82
Struts to frame	Nm	58
Strut to engine	Nm	58 (clean thread + Loctite 2701)
Rear frame to left/right of engine	Nm	42 (clean thread + Loctite 2701)
Rear frame with footrest plate to left/right of transmission	Nm	42 (clean thread + Loctite 2701)
Fairing bracket to frame	Nm	20
Side stand		
Mounting bracket to right of engine, M 12 screw	Nm	72 (clean thread + Loctite 2701)
Pivot mount to engine, left		
M 12 screw	Nm	72 (clean thread + Loctite 2701)
M 8 screw	Nm	21 (clean thread + Loctite 2701)
Pivot mount of main (centre) stand (stud bolt)	Nm	21 (clean thread + Loctite 243)
Pivot mount of main (centre) stand (machine screw)	Nm	21
Side stand to pivot mount	Nm	58 (clean thread + Loctite 2701)
Footrest plate		
Footrest plate to left/right transmission	Nm	19
Footrest plate to left of rear frame		
M 10 screw	Nm	36
M 8 screw	Nm	19
Footrest plate to right of rear frame		
M 10 screw	Nm	36
M 8 screw	Nm	19
Shift lever to footrest plate	Nm	35

Model		R 1150 RT
Connection		
51 Equipment		
Ignition/steering lock to fork bridge	Nm	20 (micro-encapsulated)
Model		R 1150 RT
Connection		
61 General electrical equipment		
Horn to holder	Nm	8 (clean thread + Loctite 243)
Horn to fairing bracket	Nm	10
Ground (earth) strap to engine block	Nm	9
Battery carrier to rubber-metal element	Nm	8
Strut to battery carrier	Nm	10



Table of operating fluids



Item	Use	Order number	Quantity
Lubricant			
Staburags NBU 30 PTM	High-performance lubricating paste	07 55 9 056 992	75 g tube
Optimoly MP 3	High-performance lubricating paste	07 55 9 062 476	100 g tube
Optimoly TA	High-temperature assembly paste	18 21 9 062 599	100 g tube
Silicone grease 300, heavy	Damping grease	07 58 9 058 193	10 g tube
Retinax EP2	Wheel, steering head and taper roller bearing grease	83 22 9 407 845	100 g tube
Contact spray	Contact spray	81 22 9 400 208	300 ml spray
Chain spray	Drive chain	72 60 2 316 676 72 60 2 316 667	50 ml spray 300 ml spray
Sealants			
3-Bond 1110 B	Surface sealant	07 58 9 056 998	5 g tube
3-Bond 1209	Surface sealant	07 58 9 062 376	30 g tube
OMNI VISC 1002	Surface sealant	07 58 1 465 170	90 g tube
Loctite 574	Surface sealant	81 22 9 407 301	50 ml tube
Loctite 577	Thread locking compound	07 58 2 328 736	5 g tube
Curil K 2	Heat-conductive sealant	81 22 9 400 243	250 g can
Adhesives and retaining agents			
Loctite 648	Joint adhesive (narrow gap)	07 58 9 067 732	5 g bottle
Loctite 638	Joint adhesive (wide gap)	07 58 9 056 030	10 ml bottle
Loctite 243	Thread retainer, medium-strength	07 58 9 056 031	10 ml bottle
Loctite 270	Thread retainer, strong	81 22 9 400 086	10 ml bottle
Loctite 2701	Thread retainer, strong	33 17 2 331 095	10 ml bottle
Loctite 454	Cyanacrylate adhesive (gel)	07 58 9 062 157	20 g tube
Cleaners			
Brake cleaner	Brake cleaner	83 11 9 407 848	600 ml spray
Metal Polish	Polish for chrome-plated parts	82 14 9 400 890	100 g tube
Testing agents			
Penetrant MR 68	Crack testing agent for aluminium housings	83 19 9 407 855	500 ml spray
Developer MR 70	Crack testing agent for aluminium housings	81 22 9 407 495	500 ml spray
Installation aids			
BMW cooling spray	Cooling spray	83 19 9 407 762	300 ml spray

00 Pre-delivery check

Contents

Page



General view of crated motorcycle	15
Checking the crated motorcycle for damage	16
In case of damage in Germany	16
In case of damage in importer markets	16
Unpacking the motorcycle	16
Assembling the motorcycle	17
Installing the front wheel	17
Installing front mudguard	17
Filling and charging the battery	18
Installing cover for windscreen adjuster and installing windscreen	20
Installing mirrors	20
Assembling case	20
Inspecting motorcycle for damage	21
Checking that delivery is complete	21
Checking engine oil level when cold, adding oil if necessary	21
Checking tightness of rear wheel studs	21
Checking tyre pressures	21
Checking headlight beam angle, adjusting if necessary	22
[Integral ABS] Performing bleed test with BMW MoDiTeC	23
Final inspection and function check	23
Final cleaning	23
Handing over the motorcycle	24



General view of crated motorcycle

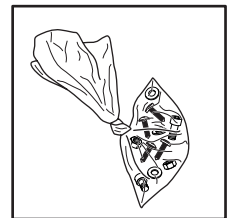
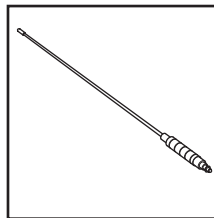
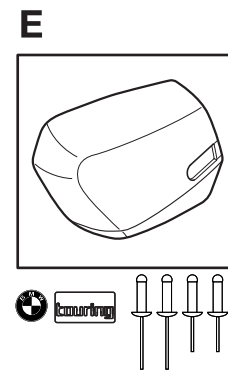
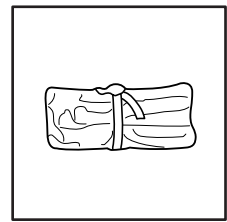
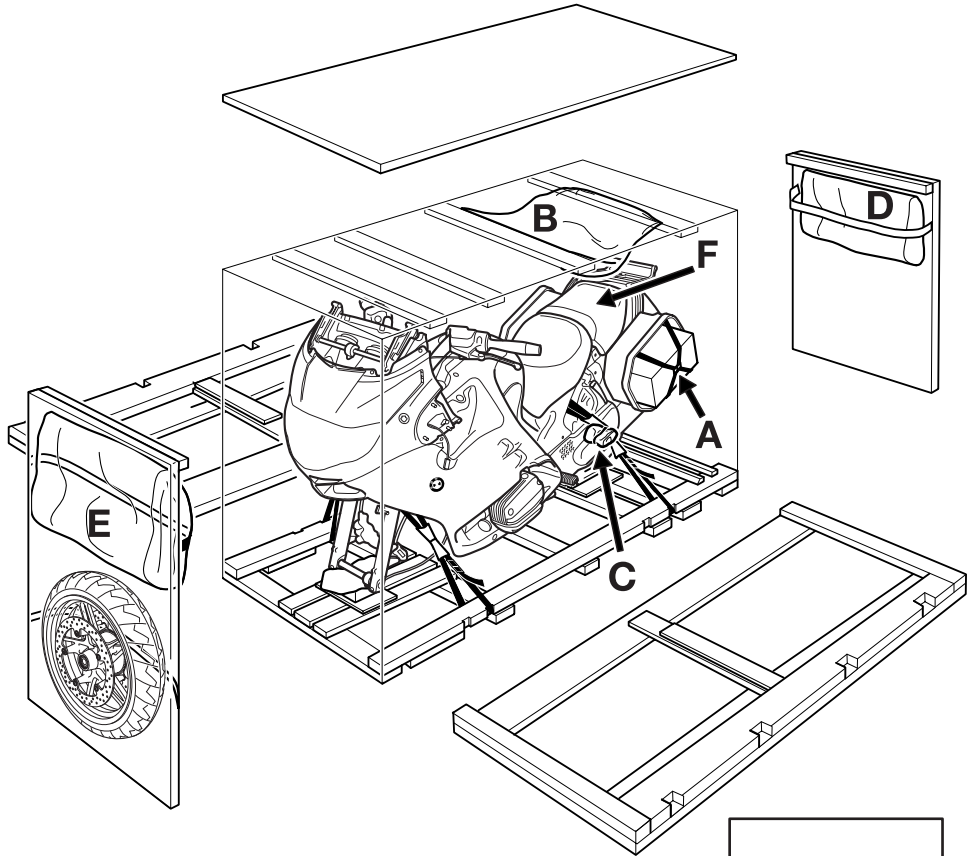
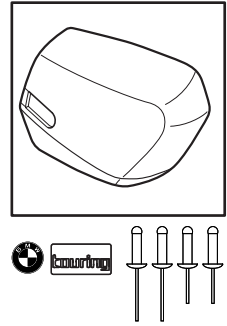
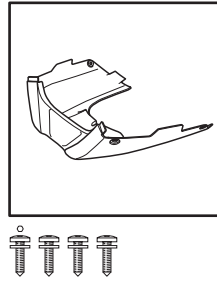
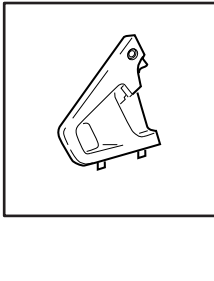
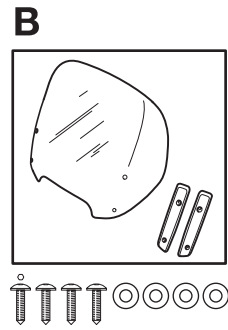
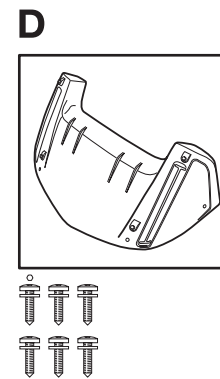
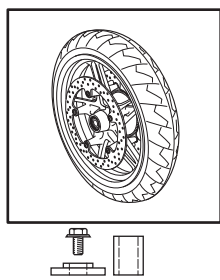
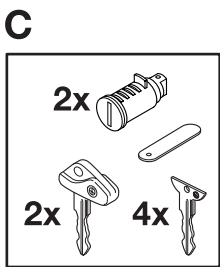
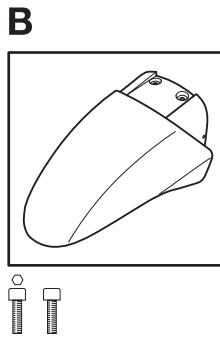
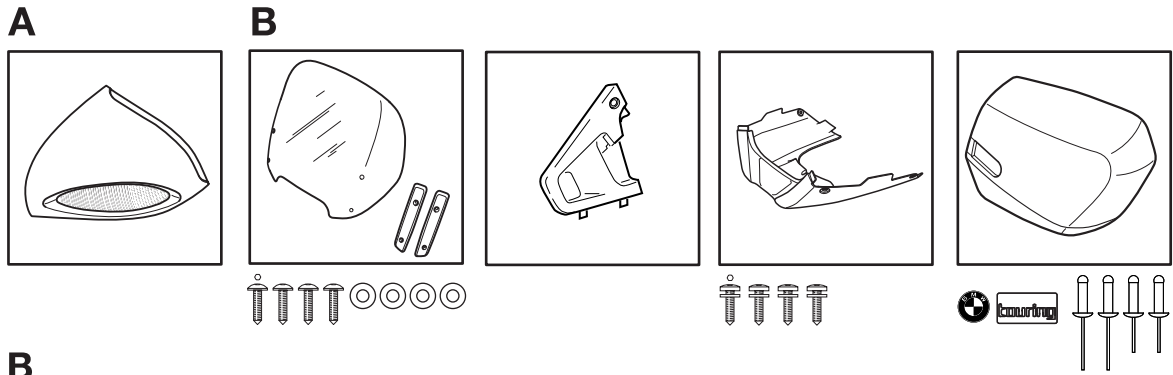

R22009010

Checking the crated motorcycle for damage

- When the motorcycle arrives, check the crated motorcycle immediately for damage and, if necessary, examine the contents for consequential damage.



In case of damage in Germany

- Note the damage on the delivery slip.
- Read the information sheet on damage in transit.
- Notify the supplier without delay (e.g. freight company or DB) and also Bavaria Wirtschaftsagentur GmbH
Abteilung ZW - 12
80788 München
Tel. +49 89/14327-632
Fax. +49 89/14327-709

In case of damage in importer markets

- Note the damage on the delivery slip.
- Comply with specific national market procedures.
In case of doubt, please submit enquiries to:
Bavaria Wirtschaftsagentur GmbH
Abteilung ZW - 12
D-80788 München
Tel. +49 89/14327-632
Fax. +49 89/14327-709
- Notify the supplier (e.g. freight company) without delay.

Unpacking the motorcycle

- Lever off the cover.
- Remove plastic covers.
- Take out the separate pack of items:
 - Front wheel
 - Case lid
 - Aerial
 - Windscreen
 - Covers
 - Engine spoiler
 - Cover for windscreen adjuster
 - Front mudguard
 - Mirrors
 - Small parts/fasteners
 - Documentation
- Remove the set of keys from the left rear footrest.
- Force off cross-struts with a suitable lever.



Attention:

Do not knock the cross-struts out or the motorcycle may be damaged.

- Remove the end-walls.
- Remove the side-walls.



Attention:

Remove any nails projecting from the base of the crate or lying on the base or on the floor.

- Dispose of the packing materials in an environmentally responsible manner as described in Circular 23/91 - Sales.

Assembling the motorcycle

Installing the front wheel



Attention:
Degrease all brake discs.

- Remove front straps.



R22000010

- Using the straps, secure the front of the motorcycle to the assembly crane, **BMW No. 46 5 640**.



Attention:
Do not damage the brake lines, Bowden cables and fairing panels.

- Raise the front of the motorcycle.



Attention:
Make sure that the motorcycle cannot topple sideways.

- Remove rear straps.
- Using the assembly crane, **BMW No. 46 5 640**, carefully push the motorcycle forward off the pallet.
- Extend the main stand and lower the motorcycle until it is resting firmly on the main stand and the rear wheel.



Warning:
Integral ABS When removing and installing the brake calipers, carefully force back the pistons only far enough to ensure that the wheel-circuit reservoir does not overflow.
If fluid escapes, top up the level in the wheel-circuit reservoir to "MAX" mark.

- Remove screws securing the front brake calipers.



Note:
Do not apply handbrake lever or footbrake lever with brake calipers removed/front wheel removed.

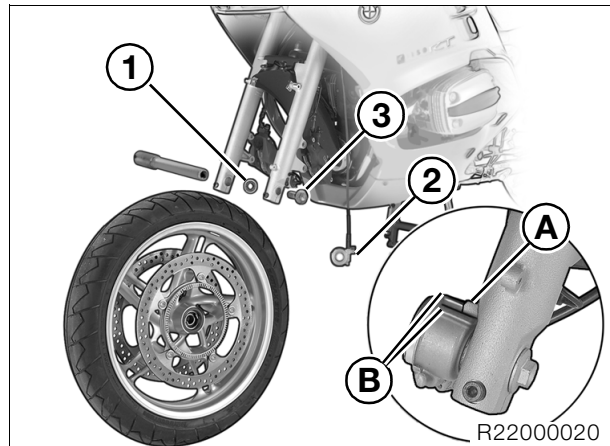

R22000020

- Install the front wheel with spacer (1) and speedometer drive (2).



Attention:
Locate stop on slider tube (A) in recess in speedometer drive (B).

- Tighten the retaining screw (3).
- Install the front brake calipers.
- Release the motorcycle from the assembly crane, **BMW No. 46 5 640**.
- Compress the front fork firmly several times.
- Tighten the clamp screws.



Warning:
The brakes are not ready for use until the brake pads have been bedded against the brake discs with the ignition switched on.



Tightening torque:

Bolt of quick-release axle	30 Nm
Clamping screws of quick-release axle	22 Nm
Brake caliper to fork slider	30 Nm

Installing front mudguard

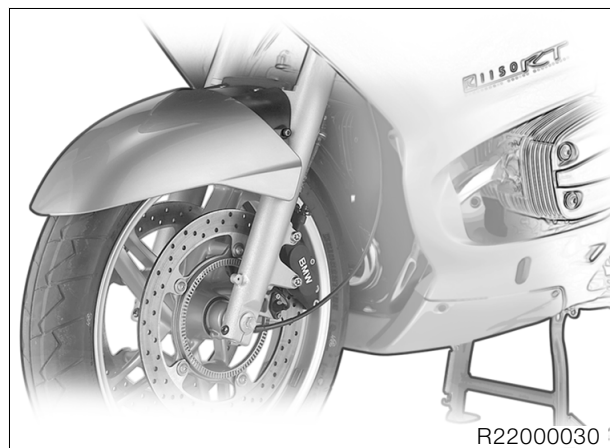

R22000030

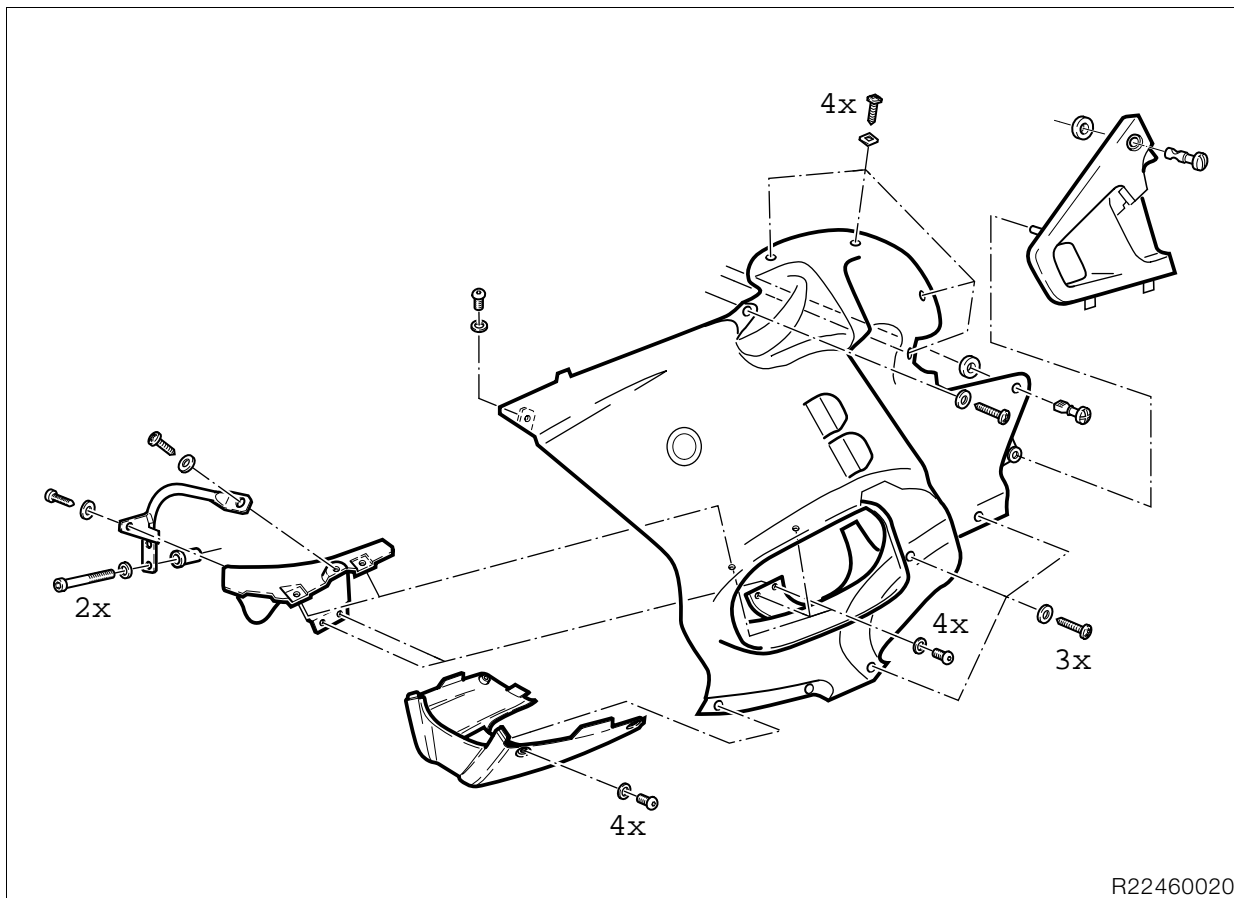

R22460020

Filling and charging the battery

- Remove seat.
- Remove left side fairing panel.
- Remove the air filter cover.
- Remove air intake pipe.
- Disengage the rubber strap holding the battery.



Warning:

Battery acid is highly caustic. It must not contact the eyes, face hands, clothing or the motorcycle's paintwork.

- Fill all the cells with pure battery acid of density 1.28 to the upper mark.
- Allow the battery to stand for approximately 30 minutes.



R22000040

- Disconnect the battery breather hose.
- Pull the battery to the left to remove.

- The battery does not achieve full charge capacity from being filled, so it has to be charged with a battery charger.



Note:

Follow the instructions for use supplied with the battery charger.

Charge current (amps)

..... 10 % of rated battery capacity (Ah)

Charging time

..... 5-10 hours

- Battery charge can be measured by checking the density of the battery acid.

Acid density

Battery full charged

..... 1.26-1.30 at a temperature of 20 °C (68 °F)

- Shake the battery slightly to allow the gas bubbles to escape.
- Wait until the battery acid has settled, check that no more bubbles rise and if necessary, top up the acid to the max. mark.
- Reinstall the plugs.
- Make a note of the charging date on the battery.

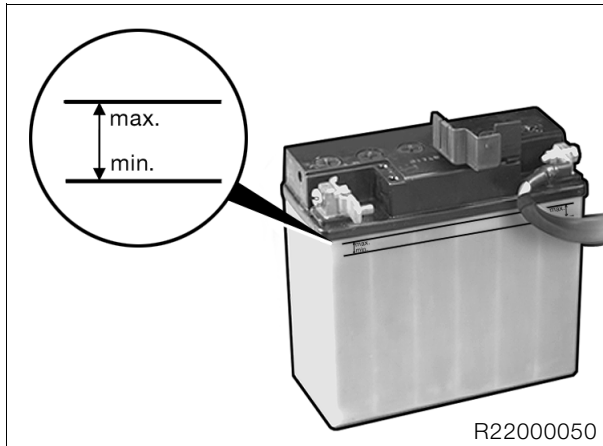

Attention:

Connect the positive battery terminal first, then the negative terminal.

- Connect the positive cable, coat with acid-proof grease and install the protective cap.
- Install the battery.
- Connect the negative cable and coat with acid-proof grease.
- Assembly is the reverse of the disassembly procedure.
- Install the left side fairing panel.
- Install the engine spoiler.
- Install the covers.

- Switch on the ignition.



Note:

After switching on the ignition, always wait for the BMW Integral ABS to complete its self-diagnosis. Do not operate the brake lever until self-diagnosis has completed.

- With the ignition switched on, bed in the brake pads against the brake discs.
- Without starting the engine, fully open the throttle once or twice so that the Motronic control unit can register the throttle-valve positions.



Note:

Disconnecting the battery means that the entries in the fault memory of the Motronic MA2.4 control unit are deleted and the adaptation values are reset. This can temporarily impair the operating characteristics when the engine is restarted.



Installing cover for windscreen adjuster and installing windscreen

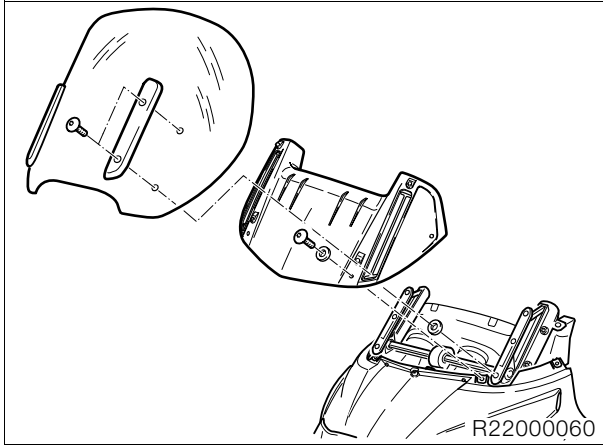

- Install the cover for the windscreen adjuster.
- Install windscreen with washers.
- Install the aerial.

Installing mirrors

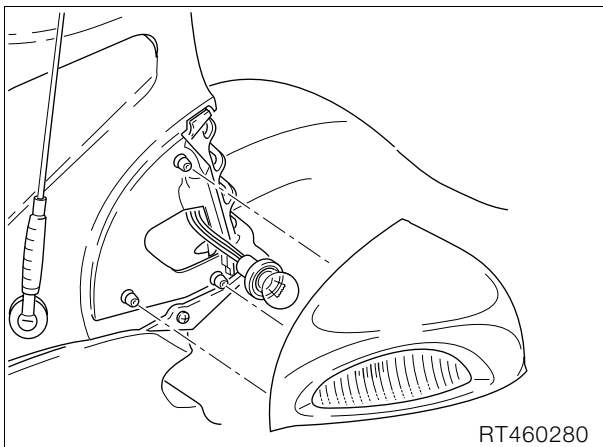

- Connect the turn indicators.
- Position the mirror at the 3 attachment points.
- Engage by pressing at the front first, then the rear.

Assembling case

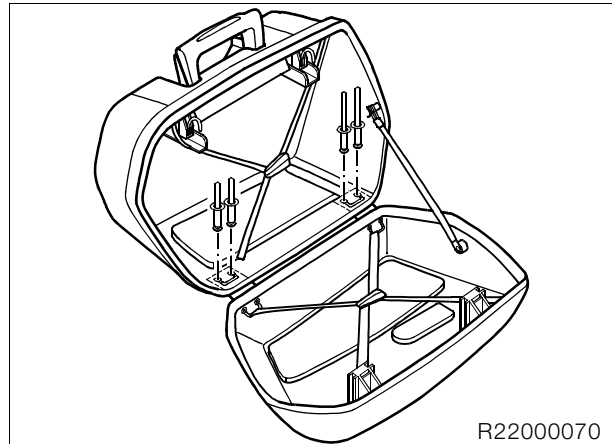

- Position the lid on the case for alignment. Open the hinges of the lid and guide them into the base with the guide hook.
- From the inside, insert the pop rivets into the base and the hinges.
 - 2x long rivets in hinge at rear, as viewed in forward direction of travel.
 - 2x short rivets in hinge at front, as viewed in forward direction of travel.
- Engage riveting tool on rivets, hold the hinge at the outside to keep it in position and secure all four rivets.
- Oil the seal in the bottom of the case, using the sponge provided for the purpose.

⚠ Attention:

Make sure that the seal is not squeezed out of shape and that the lid closes without catching.

- Carefully close the case.
- Insert the lock cylinder into the case with the key in the lock and turn the lock.
- Affix the stickers.

Inspecting motorcycle for damage

- Check for defects.
- Use the “express handling service” to notify BMW Motorrad, UX-VS-1
Fax: + 49 89-382-33220
- Rectify the fault.
- If parts are needed, order them through the usual channel.
- Costs are to be processed by the warranty claim system (stage 4). Defect codes:
 - Parts missing 10 01 00 00 00
 - Parts damaged 10 02 00 00 00
 - Incorrect parts delivered 10 03 00 00 00

Checking that delivery is complete

- All optional extras
- Toolkit
- Documentation

Checking engine oil level when cold, adding oil if necessary



Note:

The difference between the oil level indicated when the engine is at operating temperature and the oil level indicated when the engine is very cold due to extremely low outdoor temperatures can be as much as 10 mm (0.3937 in).

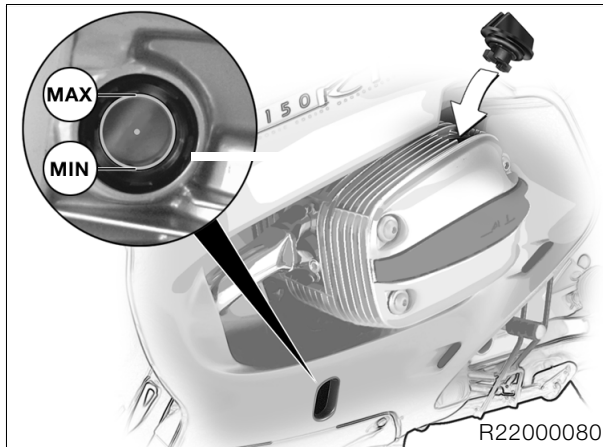

- Check oil level with the motorcycle upright.



Attention:

Never top up the engine-oil level past the “MAX” mark.

Required level:..... MAX

Checking tightness of rear wheel studs



Tightening torque:

Securing screws for rear wheel 105 Nm

Checking tyre pressures

- Check/correct tyre pressures.

Tyre pressures:

one-up front 2.2 bar (31.90 psi)
..... rear 2.5 bar (36.26 psi)

two-up front 2.5 bar (36.26 psi)
..... rear 2.9 bar (42.06 psi)

two-up + luggage front 2.5 bar (36.26 psi)
..... rear 2.9 bar (42.06 psi)

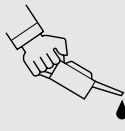

Checking headlight beam angle, adjusting if necessary

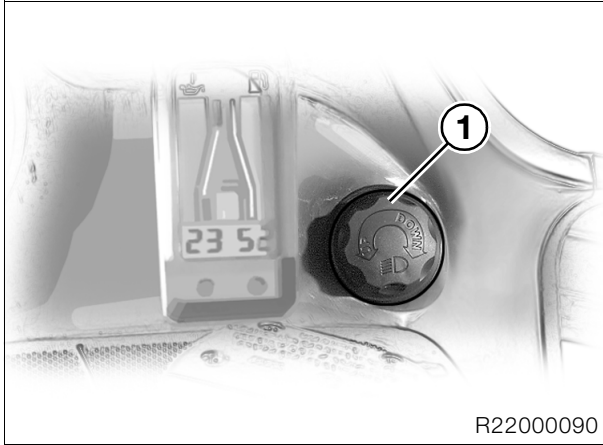

- Motorcycle on level surface.
- Rider's weight on motorcycle (approx. 85 kg/187.4 lbs).
- Turn knob (1) counter-clockwise as far as it will go.
- Check headlight beam throw.

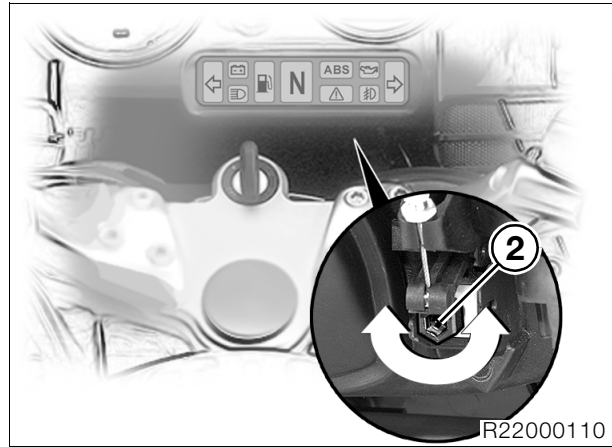

- Turn screw (2) to adjust beam throw, if necessary.

Direction of rotation, left.....further/higher
 Direction of rotation, right.....shorter/deeper

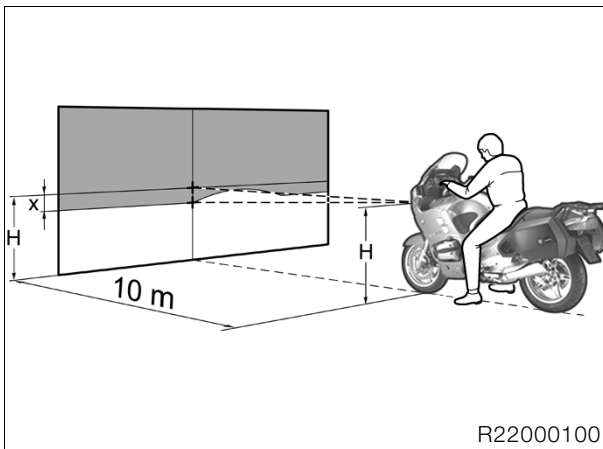

Setting for headlight beam angle adjuster

... -10 cm (-3.937 in) at a distance of 10 m (32.8 ft)

Integral ABS Performing bleed test with BMW MoDiTeC



Warning:

Self-diagnosis is not performed unless both brake levers are in their fully released positions. Prior to conclusion of the self-diagnosis, only RESIDUAL BRAKING FUNCTION is available.

Perform BMW Integral ABS self-diagnosis:

- Release the brake levers, if necessary.
- Switch on the ignition.
- With the ignition switched on, bed in the brake pads against the brake discs.

ABS warning light.....flashes at 4 Hz
General warning light ON

- Self-diagnosis is in progress

ABS warning light.....flashes at 1 Hz
General warning light OFF
– Self-diagnosis successfully completed.

Perform bleed test with BMW MoDiTeC:

- Remove front and rear seats.
- Connect the **BMW MoDiTeC** to the diagnosis connector.



Warning:

When performing maintenance and repair work on BMW Integral ABS, never pump quickly or vigorously.

- Perform bleed test.
- Perform all requisite repair work.

Perform BMW Integral ABS pull-away test:

- When a speed of 5 km/h (3 mph) is reached, the ABS warning light must go out.



Note:

The ABS warning light and the general warning light must both be OFF after successful self-diagnosis and the pull-away test.

Final inspection and function check

- Clutch
- Check gear shift action.
- Handbrake and foot brake
- Check lights and signalling equipment:
 - Front and rear parking lights
 - Instrument lighting
 - Low and high headlight beams, headlight flasher
 - Fog lamps
 - Brake light (operate brake at front and rear)
 - Turn signals left/right
 - Hazard warning lights
 - Horn
 - Telltale and warning lights
 - Instruments
- Check operation of optional extras.
- If necessary, take the motorcycle for a test ride.
- Confirm pre-delivery check in Service and Technical Booklet.
- See “Checking motorcycle for damage” if defects are found.

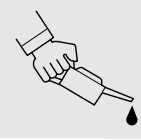

Final cleaning

- Clean the motorcycle.



Note:

Do not use a steam or high-pressure water jet. The high steam or water pressure could damage seals, the hydraulic system or electrical components.

Handing over the motorcycle

This is the ideal opportunity to familiarise the customer with the motorcycle in order to ensure the customer's satisfaction and safety.



- The following points must be demonstrated and explained to the customer:
 - documentation and stowage space
 - toolkit and stowage space
 - suspension preload adjustment to suit total weight
 - checking brake fluid/clutch operating fluid
 - provision for adjusting handlebars lever positions
 - procedure for adjusting seat
 - how to adjust the mirrors
 - controls
 - instruments and telltale lights
 - optional equipment and accessories fitted
 - features of **BMW Integral ABS**:
 - brake servo,
 - residual braking function,
 - pump noises,
 - self-diagnosis with pull-away test.

- The user must be given the following information:
 - running-in recommendations and inspection intervals
 - safety check
 - features of **BMW Integral ABS**:
 - fully integral brake,
 - brake-fluid levels in the control circuits remain constant despite brake-pad wear.
 - the clutch fluid level rises gradually as the motorcycle is ridden (clutch lining wear)
 - Always check the oil level when the engine is at operating temperature, because the difference between the oil level indicated when the engine is at operating temperature and the oil level indicated when the engine is very cold due to extremely low outdoor temperatures can be as much as 10 mm (0.3937 in). After switching off the engine at operating temperature, wait at least 5 minutes for the oil to drain back into the sump. Checking the oil level just after the engine has been run or when it is not properly warm will falsify the reading.

00 Maintenance

Contents

Page

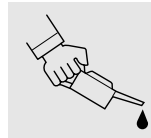

Key to maintenance intervals	29
Reading the BMW MoDiTeC fault code memory	29
(Inspections I, II, III and IV)	29
Integral ABS: Performing bleed test with BMW MoDiTeC	29
(Inspections I, II, III and IV)	29
Changing engine oil, replacing oil filter element	30
(Inspections I, II, III and IV)	30
Changing oil in gearbox	31
(Inspections III and IV)	31
or at the latest every 2 years	31
Changing the oil in the rear wheel drive	31
(Inspections I, III and IV)	31
every 40,000 km (24,000 miles) or at the latest every 2 years	31
Replacing fuel filter	32
(Inspection III)	32
In normal operating conditions every 40,000 km (24,000 miles); if fuel quality is poor every 20,000 km (12,000 miles)	32
Checking battery fluid level and topping up if necessary; cleaning and greasing the battery posts	34
(Inspections III and IV)	34
Replacing intake air filter element	35
(Inspection III)	35
in very dirty and dusty operating conditions, replace every 10,000 km (6,000 miles) or even more frequently if necessary	35
Replacing Poly-V belt	35
(Inspection III)	35
every 60,000 km (36,000 miles)	35
Checking brake fluid level	36
(Inspections II and III)	36
Front brake	36
Rear brake	36
Checking brake system for correct operation and freedom from leaks; repairing/replacing if necessary	36
(Inspection III)	36



Checking brake pads and discs for wear/replacing	37
(Inspections II and III)	37
Checking brake pads for wear	37
Brake pads, front brake	37
Brake pads, rear brake	37
Checking brake disc wear	38
Replacing brake pads	38
Brake pads, front brake	38
Brake pads, rear brake	39
Changing/bleeding brake fluid in wheel circuit	40
Change brake fluid in wheel circuit once a year	40
(Inspection IV)	40
Bleeding/changing brake fluid in front wheel circuit	40
Instructions for filling front wheel circuit reservoir	42
Bleeding/changing brake fluid in rear wheel circuit	44
Instructions for filling rear wheel circuit reservoir	46
Changing/bleeding brake fluid in control circuit	48
Change brake fluid in control circuit every 2 years	48
(Inspection IV)	48
Bleeding/changing brake fluid in front control circuit	48
Bleeding/changing brake fluid in rear control circuit	50
Checking clutch operating fluid level	51
(Inspections II and III)	51
Changing the clutch fluid	52
(Inspection IV)	52
every 2 years at the latest	52
Checking tightness of rear wheel studs	53
(Inspection I)	53
Checking rear wheel bearing play by tilting wheel	53
(Inspection III)	53
Checking swinging arm bearings, adjusting if necessary	53
(Inspections I and III)	53
Greasing the side stand pivot	53
(Inspections I, II and III)	53
Checking function of side stand contact switch	53
(Inspections I, II, III and IV)	53
Checking/replacing spark plugs	54
(Inspection II) check/(Inspection III) replace	54
Tightening cylinder heads	54
(Inspection I)	54

Contents

Page

Checking/adjusting valve clearances55
(Inspections I, II and III)55

Checking freedom of throttle cable, checking for chaffing and kinks, replacing if necessary, Checking throttle-cable play
Checking and adjusting idle speed and throttle-valve synchronisation55
(Inspections I, II and III)55

Final inspection with road safety and functional check57
(Inspections I, II, III and IV)57
Road safety check57
Roadworthiness check57



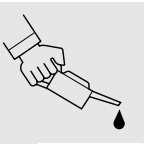

Key to maintenance intervals

- BMW Inspection at 1,000 km (600 miles) **I**
- BMW Service every 10,000 km (6,000 miles) **II**
- BMW Inspection every 20,000 km (12,000 miles) **III**
- BMW Annual Service **IV**

00 13 624 Reading the BMW MoDiTeC fault code memory

(Inspections I, II, III and IV)

- Remove front and rear seats.
- Connect the **BMW** MoDiTeC to the diagnosis connector.
- Read all fault memories.
- Perform all requisite repair work.



Integral ABS: Performing bleed test with BMW MoDiTeC

(Inspections I, II, III and IV)

- Remove front and rear seats.
- Connect the **BMW** MoDiTeC to the diagnosis connector.



Warning:

When performing maintenance and repair work on BMW Integral ABS, never pump quickly or vigorously.

- Perform bleed test.
- Perform all requisite repair work.

00 11 209 Changing engine oil, replacing oil filter element

(Inspections I, II, III and IV)



Note:

If the motorcycle is ridden only for short distances or outside temperatures are below 0°C (32°F) change the oil and replace the oil filter element every 3 months, or not later than every 3,000 km (1,800 miles).



- Change the oil at operating temperature.

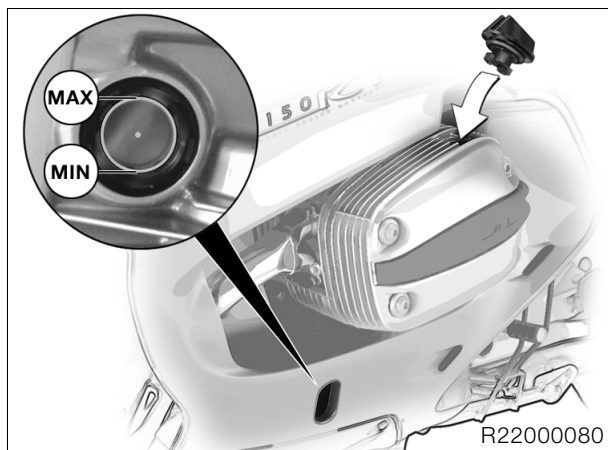

- Remove screw plug.
- Remove oil drain plug and drain off oil.

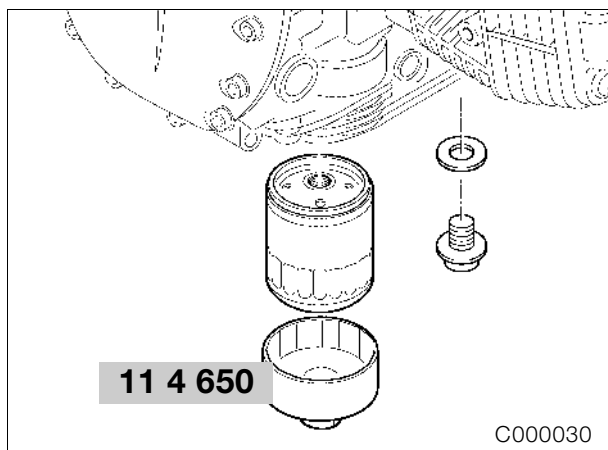

- Use oil filter wrench, **BMW No. 11 4 650**, to remove the oil filter.
- Coat sealing ring on new oil filter element with oil and install filter.
- Reinstall the oil drain plug with a new sealing ring.
- Refill with oil to correct level.

- Insert and tighten the screw plug.



Attention:

Never top up the engine-oil level past the "MAX" mark.



Tightening torque:

Oil filter.....	11 Nm
Oil drain plug.....	32 Nm

Engine oil capacities:

with oil filter renewal 3.75 l (6.60 Imp. pints/3.96 US quarts)
without oil filter renewal 3.50 l (6.16 Imp. pints/3.69 US quarts)
Quantity of oil between MIN and MAX marks 0.50 l (0.88 Imp. pints/0.52 US quarts)

Engine oil grade:

Brand-name HD oil for spark-ignition engines, API classifications SF, SG, SH; combination with CD or CE specification.

Brand-name HD oil of CCMC classification G4, G5; amendment PD2 is permissible.

00 11 229 Changing oil in gearbox

(Inspections III and IV)
or at the latest every 2 years

- Change the gearbox oil at operating temperature.

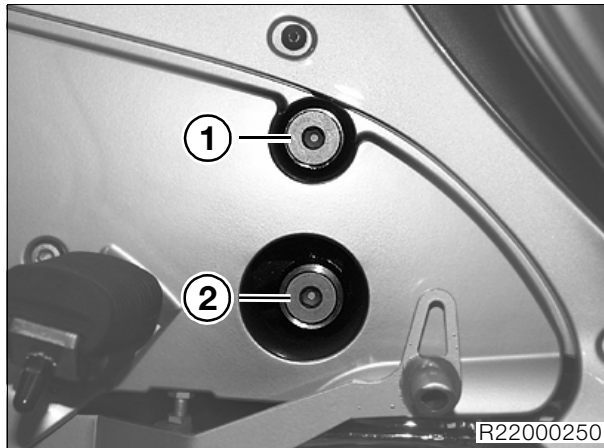

- Remove oil filler plug (1).
- Push in oil drain tube, **BMW No. 23 4 680**, and turn it to the right.
- Remove oil drain plug (2) and allow the oil to drain out.
- Reinstall the oil drain plug with a new sealing ring.
- Fill with gearbox oil.
- Insert oil filler plug with new seal.

Tightening torque:

Oil drain plug 30 Nm
Oil filler plug 30 Nm

Quantity:

to bottom edge of filler neck
..... approx. 0.8 l (1.41 Imp. pints/0.85 US quarts)

Oil grade for gearbox:

Brand-name hypoid gear oil, SAE 90, API class GL 5

00 11 229 Changing the oil in the rear wheel drive

(Inspections I, III and IV)
every 40,000 km (24,000 miles) or at the latest every 2 years

- Change the gearbox oil at operating temperature.

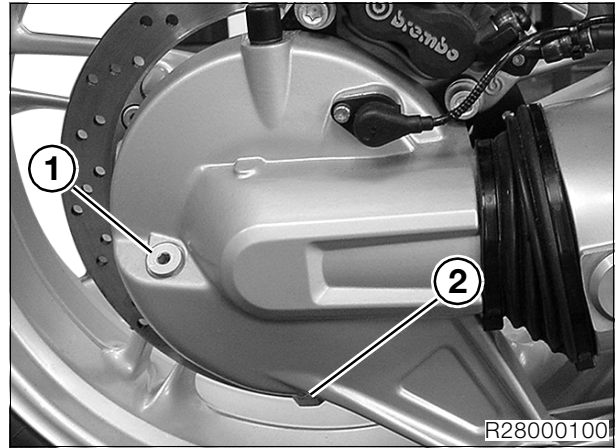

Attention:

Do not allow oil to drip onto the rear tyre.

- Remove oil filler plug (1).
- Remove oil drain plug (2) and allow the oil to drain out.
- Reinstall the oil drain plug with a new sealing ring.
- Fill with gearbox oil.
- Insert oil filler plug with new seal.

Tightening torque:

Oil drain plug 23 Nm
Oil filler plug 23 Nm

Quantity:

to bottom of thread in oil filler hole
..... approx. 0.25 l (0.44 Imp. pints/0.26 US quarts)

Oil grade for rear wheel drive:

Brand-name hypoid gear oil, SAE 90, API class GL 5

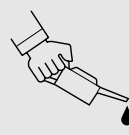

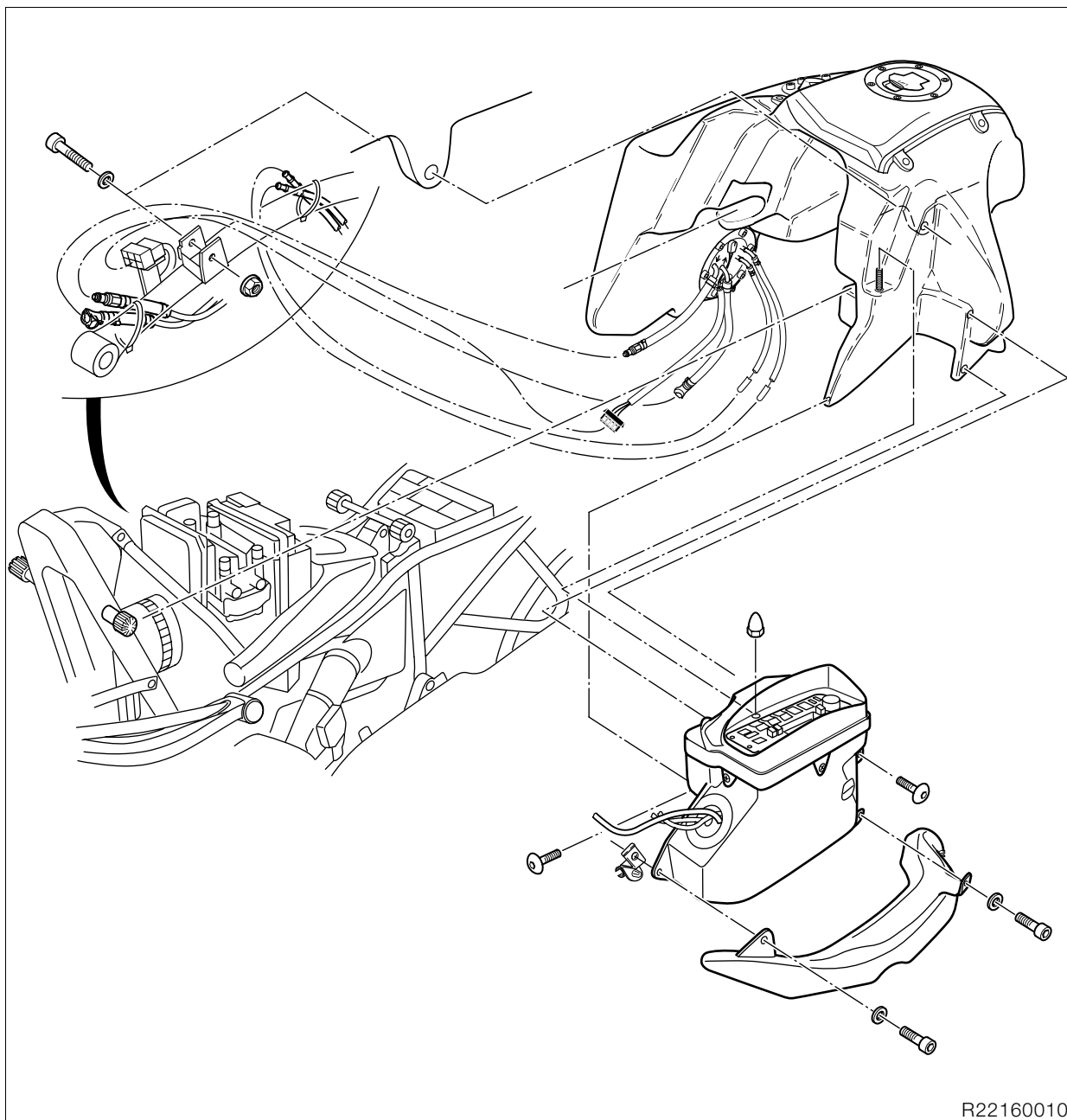

R22160010

16 12 008 Replacing fuel filter

(Inspection III)

In normal operating conditions every 40,000 km (24,000 miles); if fuel quality is poor every 20,000 km (12,000 miles)

- Remove front and rear seats.
- Remove left and right side sections of fairing.
- Disengage stowage compartment and lift it up to remove.
- Use a cable tie to secure the stowage compartment to the motorcycle.



Warning:

Fuel is flammable and a hazard to health. Observe relevant safety regulations.

- Remove screw securing fuel tank.

- Disconnect breather and overflow hoses.
- Disconnect quick-connect adapters of the fuel lines.
- Disconnect the plug of the fuel pump.
- Drain fuel tank.



Note:

To avoid damaging the paintwork of the fuel tank, lay a cloth between the fork bridge and the fuel tank.

- Pull fuel tank up and to the rear to remove.
- Remove fuel pump unit.

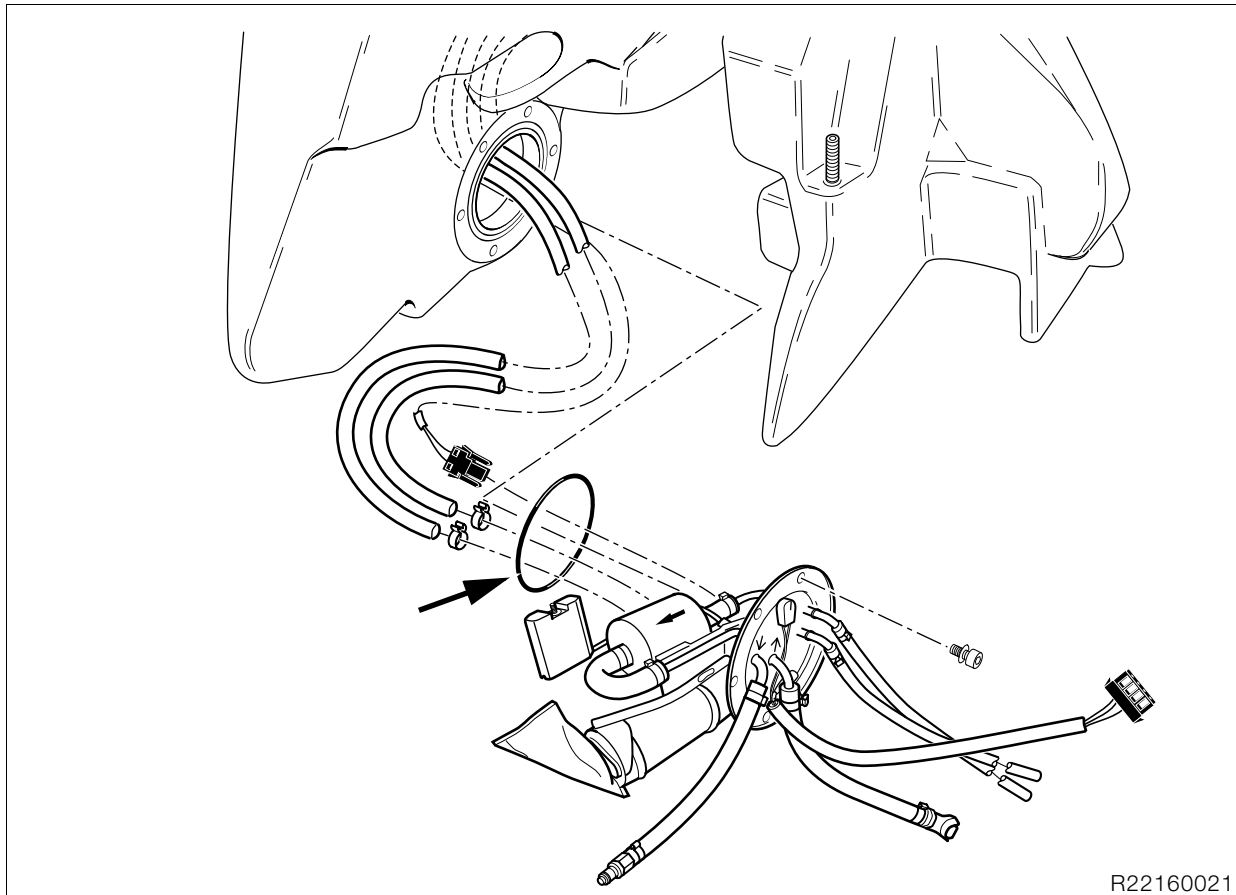

R22160021

- Disconnect hoses from fuel filter.
- Install new fuel filter.

- Installation is the reverse of the removal procedure.



Attention:

Note correct direction of flow through fuel filter.



Note:

Make sure that breather lines are correctly routed.

- Secure non-reusable hose clips with pliers, **BMW No. 13 1 500**.



Attention:

Make sure O-ring (arrow) is in perfect condition. After installing, check fuel pump unit for leaks.



Tightening torque:

Fuel pump unit to fuel tank 5 Nm
 Fuel tank to rear frame 22 Nm

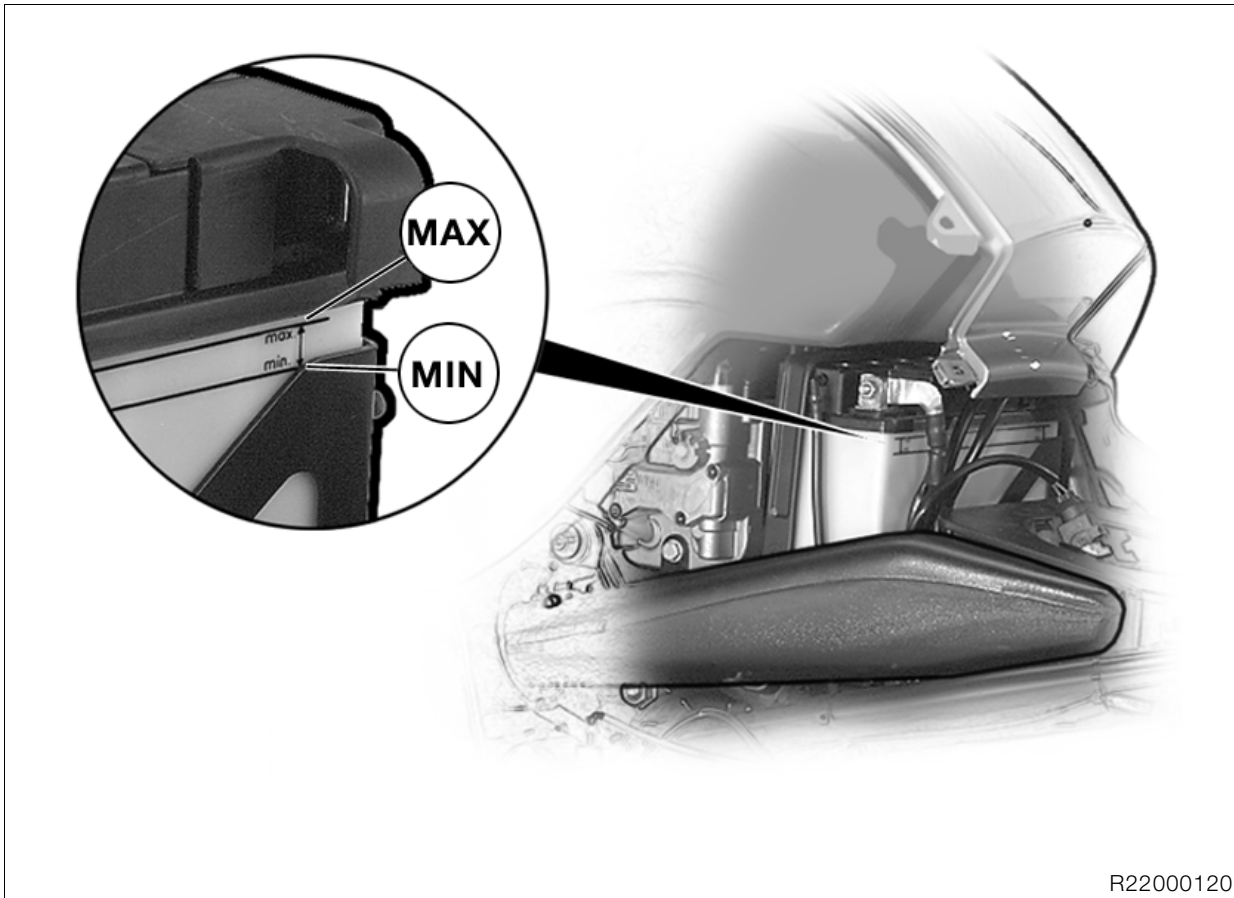

R22000120

61 20 029 Checking battery fluid level and topping up if necessary; cleaning and greasing the battery posts

(Inspections III and IV)



Warning:

Battery acid is highly caustic. It must not contact the eyes, face hands, clothing or the motorcycle's paintwork.

- Remove front and rear seats.
- Check the battery fluid level.



Note:

Remove the battery if the acid level is incorrect or cannot be read correctly.

- Remove the left side case.
- Remove left cover and side trim panel.
- Remove the air filter cover.
- Remove air intake pipe.
- Disengage the rubber strap holding the battery.
- Disconnect the battery breather hose.



Attention:

Disconnect the negative battery terminal first, then the positive terminal.



Note:

Disconnecting the battery means that the entries in the fault memory of the Motronic MA2.4 control unit are deleted and the adaptation values are reset. This can temporarily impair the operating characteristics when the engine is restarted.

- Disconnect the negative terminal of the battery.
- Pull the battery to the left to remove.
- Disconnect the positive terminal of the battery.
- If necessary, top up the acid level to the "MAX" mark with distilled water.
- Clean and grease the battery terminals.
- Installation is the reverse of the removal procedure.
- Switch on the ignition.
- Without starting the engine, fully open the throttle once or twice so that the Motronic control unit can register the throttle-valve positions.



Attention:

Connect the positive battery terminal first, then the negative terminal.

Acid proof battery-post grease:

.....e.g. Bosch Ft 40 V1

13 72 000 Replacing intake air filter element

(Inspection III)
in very dirty and dusty operating conditions,
replace every 10,000 km (6,000 miles) or even
more frequently if necessary

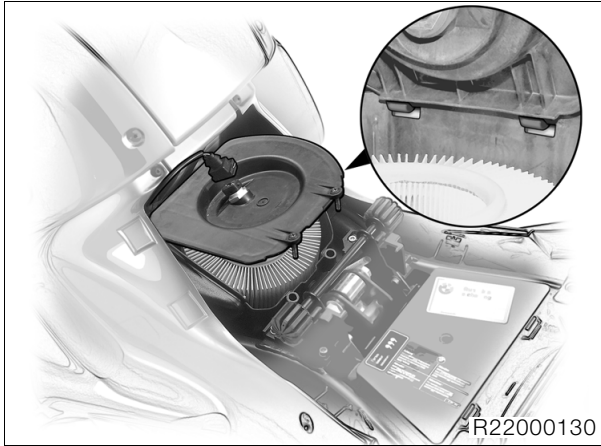

- Open clips securing air filter cover.
- Replace air filter element.
- Close air filter cover.

12 31 240 Replacing Poly-V belt

(Inspection III)
every 60,000 km (36,000 miles)

- Remove left side fairing panel.
- Remove front intake pipe.
- Disengage fairing bracket from end cover on left.

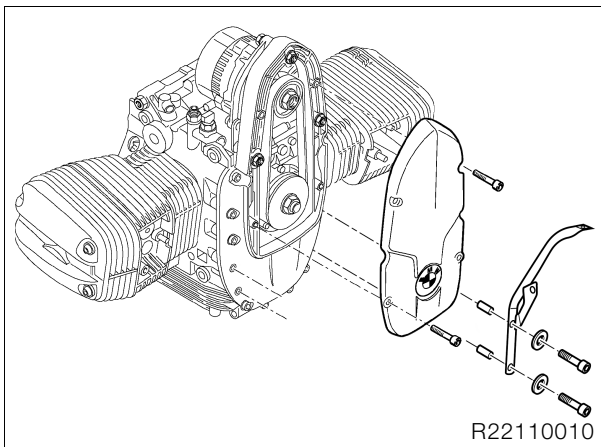

- Remove front cover.

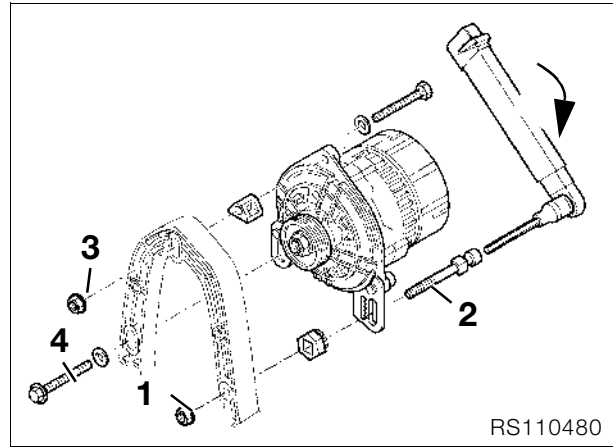

- Slacken alternator securing screws (1,3,4).
- Remove old Poly-V belt.



Note:

Loop Poly-V belt over crankshaft belt pulley first, then over alternator belt pulley.

- Install new Poly-V belt.

Poly-V belt adjusting procedure:

- Place the Poly-V belt in position, tension it and turn the engine over once, then relieve belt tension.

Poly-V belt tensioning procedure:

- 1 Slightly tighten hex nut (1) on adjusting screw (2) by hand (**do not use tools**).
- 2 Tighten adjusting screw (2) with a torque wrench and keep preload applied.
- 3 Tighten upper retaining nut (3), then remove torque wrench from adjusting screw.
- 4 Tighten all screws and nuts.



Tightening torque:

Preload for Poly-V belt	8 Nm
Belt pulley to alternator	50 Nm
Belt pulley to crankshaft	50 Nm
Alternator to alternator support cover.....	20 Nm

Checking brake fluid level

(Inspections II and III)



Note:

The brake fluid level in the sight glass/brake fluid reservoirs of control circuits remains constant despite wear of the brake pads. If the level drops below the MIN mark, this indicates some other fault.



Front brake

- Place the motorcycle on its centre stand.
- Turn the handlebars fully to the **left**.
- Check brake fluid level at sight glass.

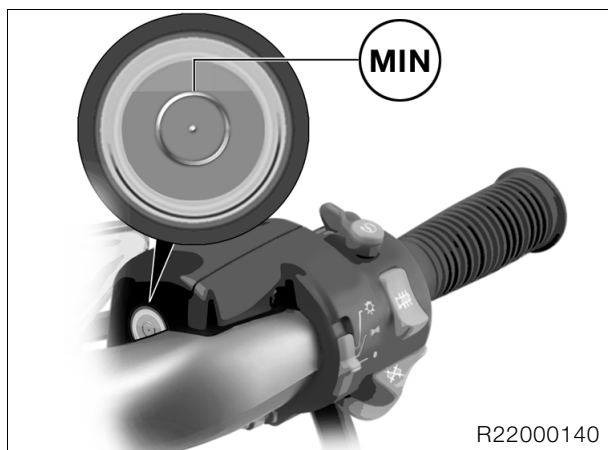

Required level

not below MIN
(top edge of the marking ring)

- Correct the fluid level if necessary.

Brake fluidDOT 4

Rear brake

- Place the motorcycle on its centre stand.
- Remove case and right trim panel.
- Check the brake fluid level.

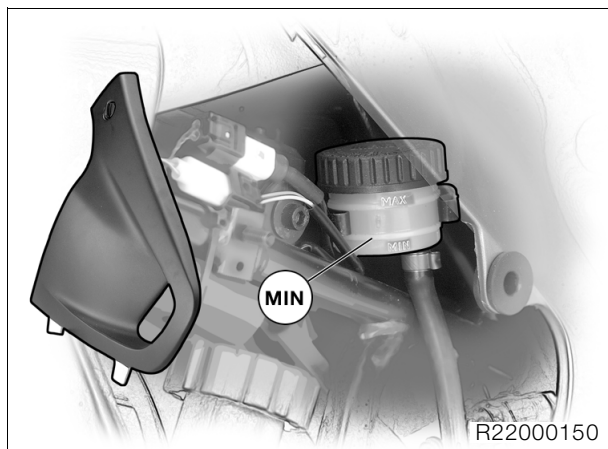

Required level

not below MIN

- Correct the fluid level if necessary.

Brake fluidDOT 4

Checking brake system for correct operation and freedom from leaks; repairing/replacing if necessary

(Inspection III)

- Check all brake lines and their holders for damage and correct positioning.
- Wipe down all threaded unions on the brake lines and check them.
- Switch on the ignition.



Note:

After switching on the ignition, always wait for the BMW Integral ABS to complete its self-diagnosis. Do not operate the brake lever until self-diagnosis has completed.



Warning:

When performing maintenance and repair work on BMW Integral ABS, never pump quickly or vigorously.

- Apply the brake hard and hold on in this position for a short time.
- After this, inspect the brake lines for leaks.



Warning:

Defective lines and threaded unions in the brake system must always be replaced without delay.

Checking brake pads and discs for wear/replacing

(Inspections II and III)

Checking brake pads for wear

Brake pads, front brake

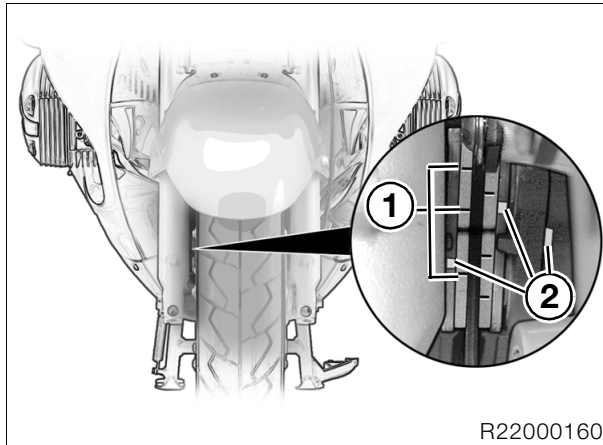

- Visually inspect the brake pads.
 - Wear indicators (1) must be clearly visible.
- If necessary, check/measure thickness of brake pads.



Attention:

Do not permit brake pad thickness to fall below the minimum value. Always replace the brake pads as a complete set.

Minimum pad thickness: 1.0 mm (0.0393 in)

- Check that colour codes of brake pads and brake calipers (2) match.

Colour code: white

Brake pads, rear brake

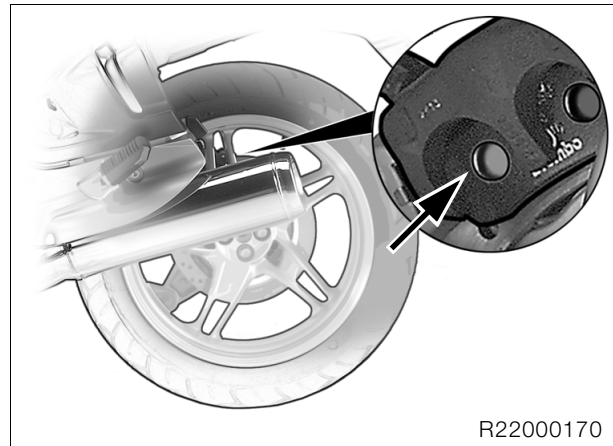

- Visually inspect the brake pads.
 - Make sure that the brake disc is not visible through the bore (arrow) in the inner brake pad.
- If necessary, check/measure thickness of brake pads.



Attention:

Do not permit brake pad thickness to fall below the minimum value. Always replace the brake pads as a complete set.

Minimum pad thickness: 1.0 mm (0.0393 in)

- If the brake disc is visible through the bore in the wheel-side brake pad, the brake lining is worn to its minimum permissible thickness.

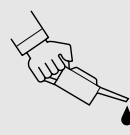

Checking brake disc wear

- Carefully check the brake discs for cracks, damage, deformation and scoring.



- Measure the thickness of the brake discs at several points with a caliper gauge.

Brake disc wear limit:

front:..... 4.5 mm (0.177 in)

rear:..... 4.5 mm (0.177 in)

Replacing brake pads

34 11 008 Brake pads, front brake



Attention:

Integral brakes, the rear brake must be ready for use.

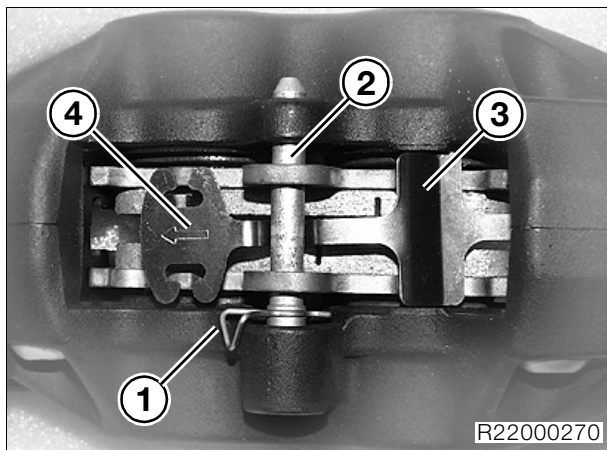

- Remove the split-pin keeper (1) from grub screw (2).

- Remove grub screw (2) and spring (3).



Attention:

Integral ABS Press back pistons on only one side of the brake caliper. Allow the brake pad on the opposite side to remain in the caliper during this process.

Make sure that the fluid level in the wheel-circuit reservoir does not rise above "max".

Risk of fluid escaping.

If fluid escapes, proceed in accordance with "instructions for filling reservoir".

- Press back piston with inner brake pad only far enough to allow the new brake pad to be slipped into position.
- Remove remaining old brake pad and insert new brake pad.
- Press back piston with outer brake pad only far enough to allow the new brake pad to be slipped into position.
- Remove remaining old brake pad and insert new brake pad.



Note:

After switching on the ignition, always wait for the BMW Integral ABS to complete its self-diagnosis. Do not operate the brake lever until self-diagnosis has completed.

- After replacing the pads of a caliper, always bed in the new brake pads with the ignition switched on.



Note:

Note position and arrow (4) of spring (3).

- Install grub screw (2) and spring (3).
- Reinsert the split-pin keeper (1) in the groove in grub screw (2).
- Check operation of the brake system with the ignition switched on.



Tightening torque:

Grub screw in front brake caliper 7 Nm

Colour code:

Brake pads/brake caliperswhite

34 21 200 Brake pads, rear brake



Attention:

Integral brakes, the front brake must be ready for use.

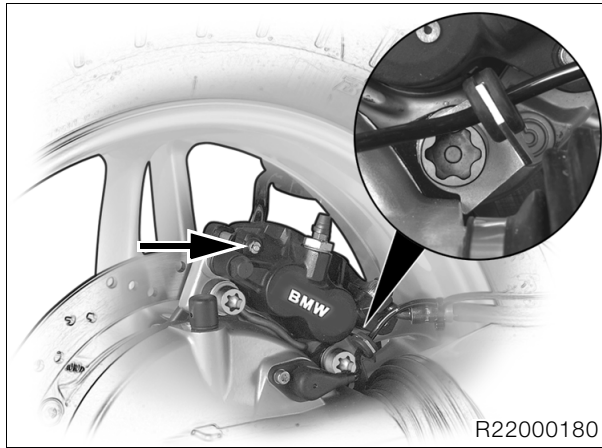

R22000180

- Remove keeper (arrow) from retaining pin.
- Drive the retaining pin out towards the wheel side.
- Remove brake caliper.
- Remove brake pads.



Attention:

Integral ABS Press back pistons in brake caliper brake pad only far enough to allow the brake disc to be slipped in.

Make sure that the fluid level in the wheel-circuit reservoir does not rise above "max".

Risk of fluid escaping.

If fluid escapes, proceed in accordance with "instructions for filling reservoir".

- Force back the pistons.



R22000280

- Check that spring is correctly positioned and secure.
 - Engraved arrow (arrow) points in direction of travel.

- Installation is the reverse of the removal procedure.
- Check operation of the brake system with the ignition switched on.



Tightening torque:

Brake caliper to rear wheel drive 40 Nm



34 00 090 Changing/bleeding brake fluid in wheel circuit

Change brake fluid in wheel circuit once a year (Inspection IV)



Warning:

All repair and maintenance work on the BMW Integral ABS must be performed by trained, qualified specialists. Comply with all maintenance and repair instructions and always work through the various steps in the correct order. Use only new brake fluid from freshly opened containers.



Note:

This description applies for the brake filling and bleeding unit with extraction of the brake fluid by partial vacuum. If other devices are used, comply with their manufacturers' instructions.

34 00 070 Bleeding/changing brake fluid in front wheel circuit



Attention:

Integral brakes, the rear brake must be ready for use.

- Remove fuel tank.



Attention:

Do not allow brake fluid to come into contact with painted parts of the motorcycle as brake fluid destroys paint.

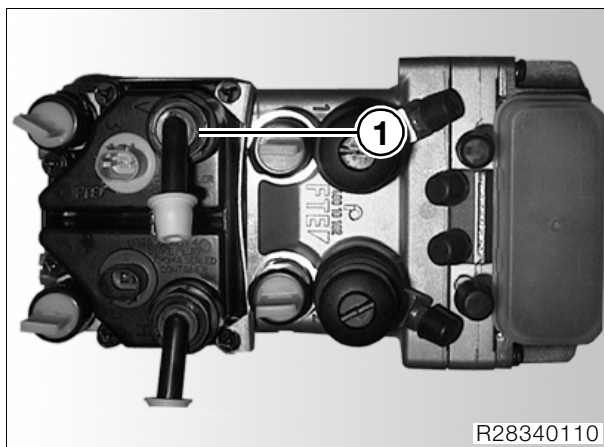

- Open front wheel-circuit reservoir (1).

- Draw off the old brake fluid from the wheel-circuit reservoir.
- Remove front brake pads (left and right).



Attention:

Install piston resetting tool, **BMW No. 34 1 531**, only when the cap has been removed from the wheel-circuit reservoir.

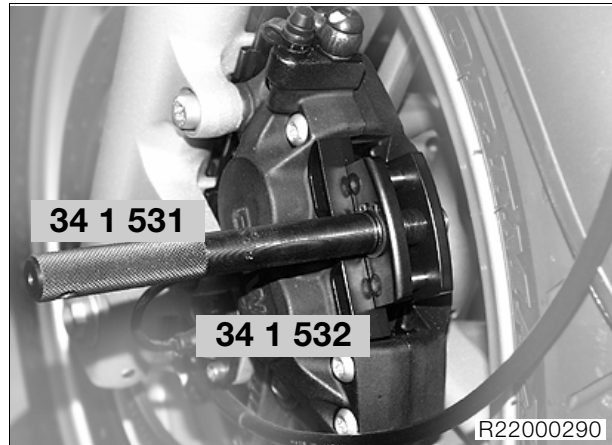

Attention:

Do not scrape the wheel – mask it off if necessary.

- Use resetting tool, **BMW No. 34 1 531**, and locator, **BMW No. 34 1 532**, to force the pistons in the left and right brake calipers all the way back and hold them in this position.
- Wrap cloths around the left and right brake calipers.
- **[Bleeding only]** Bleed the front wheel circuit. (→ 00.43)
- Draw off the old brake fluid from the wheel-circuit reservoir.

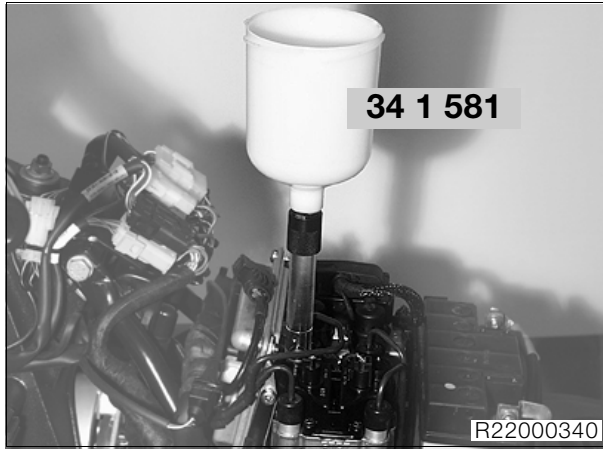

- Screw container, **BMW No. 34 1 581**, onto front wheel circuit reservoir.
- Slowly fill container, **BMW No. 34 1 581**, with new brake fluid until it is approximately 1/2 full.
- Connect the brake bleeding device to the bleed screw of the left brake caliper, but **do not switch on** the device.



Note:

If necessary, use a cable tie to secure the bleed hose to the bleed screw.

- Switch on the ignition.



Note:

After switching on the ignition, always wait for the BMW Integral ABS to complete its self-diagnosis. Do not operate the brake lever until self-diagnosis has completed.

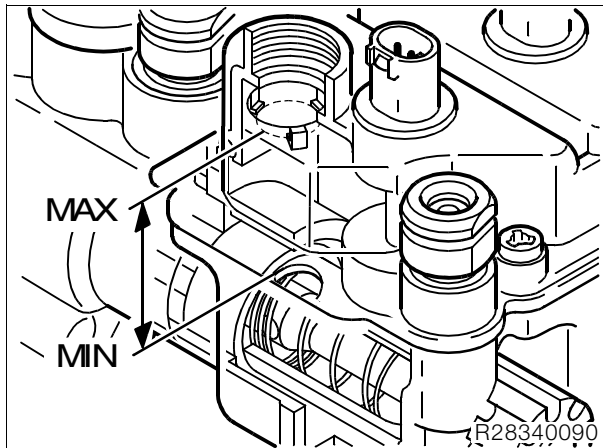

Attention:

The brake fluid must always be visible in the container, because the piston in the base of the wheel-circuit reservoir must always be covered by the fluid. The procedure must be repeated if the fluid drops below the “min” level.

- Very gently pull the handbrake lever until the pump just starts up.
- Open the bleed screw, while topping up the container with new brake fluid if necessary.
- Pump out the brake fluid with virtually no pressure to begin with, then vary the brake pressure.

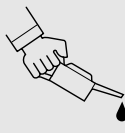

Note:

The higher the brake pressure the faster the fluid is pumped through the system, which means that the level in the wheel-circuit reservoir drops all the more rapidly.

- Pump off brake fluid until it emerges clear and free from air bubbles.
- Close the bleed screw.
- Release the brake.
- Disconnect the brake bleeding device from the bleed screw.
- Connect the brake bleeding device to the bleed screw of the right brake caliper, but **do not switch on** the device.



Note:

If necessary, use a cable tie to secure the bleed hose to the bleed screw.

- The procedure for changing the brake fluid in the right brake caliper is the same as that for the left caliper.
- When the brake fluid is clear and free of bubbles, continue pumping until the fluid in the container just disappears from view.
- Close the bleed screw.
- Release the brake and switch off the ignition.
- Disconnect the brake bleeding device from the bleed screw.
- Disconnect the container from the wheel-circuit reservoir.



Attention:

After changing and/or bleeding the brakes, always top up the fluid in the wheel-circuit reservoir to the correct level in accordance with the instructions.

Instructions for filling front wheel circuit reservoir



Attention:

Integral brakes, the rear brake must be ready for use.

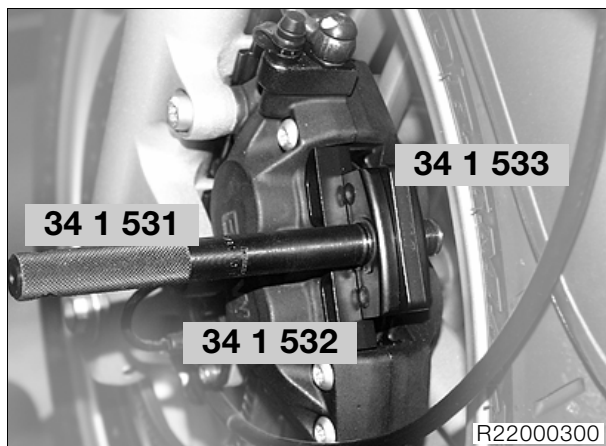

- Top up fluid in front wheel-circuit reservoir to “MAX” mark if necessary
- Install adapters 22, **BMW No. 34 1 533**, in resetting tool, **BMW No. 34 1 531/532**, for both front brake calipers, and tighten the resetting tool until the adapters are secure.



Attention:

The piston in the base of the wheel-circuit reservoir must always be covered by the fluid, as otherwise air can be drawn into the brake system. Bleed the system again if this happens.

- Switch on the ignition.



Note:

After switching on the ignition, always wait for the BMW Integral ABS to complete its self-diagnosis. Do not operate the brake lever until self-diagnosis has completed.

- Pull handbrake lever until the pistons of the front brake calipers are in contact with resetting tool, **BMW No. 34 1 531**.

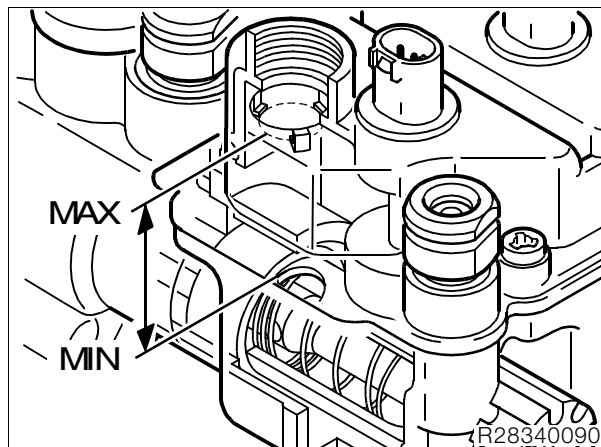

- Top up the fluid in the wheel-circuit reservoir until one of the three protrusions in the filler neck just touches the surface of the fluid (arrow).
- Screw container, **BMW No. 34 1 581**, onto front wheel circuit reservoir.
- Remove adapter, **BMW No. 34 1 533**, and force back pistons far enough to allow the brake pads to be fitted.
- Install front brake pads.
- With the ignition switched on, bed in the brake pads against the brake discs.
- Disconnect the container from the wheel-circuit reservoir.
- Hand-tighten cap of front wheel-circuit reservoir.
- Check the function of the brake system.



Attention:

After all the work on the brake system has been completed, run a bleed test using the **BMW MoDiTeC** and check the fault code memory!

- Install fuel tank.

Brake fluidDOT 4



Tightening torque:

Bleed screw in front brake caliper 7 Nm

Only bleeding the front wheel circuit

- Draw off the old brake fluid from the wheel-circuit reservoir.
- Remove left and right brake pads, force back the brake pistons and secure the pistons in this position.
- Wrap cloths around the left and right brake calipers.



Attention:

Integral brakes, the rear brake must be ready for use.

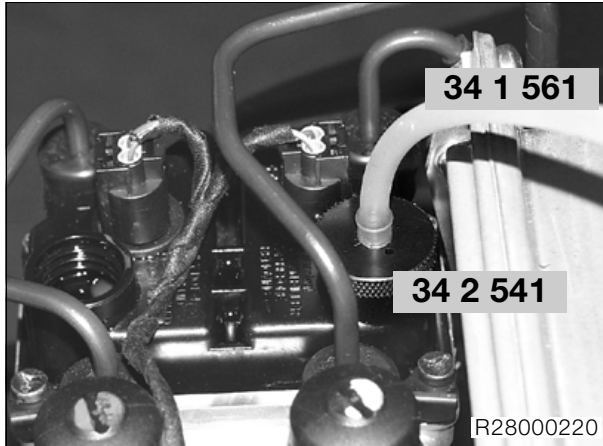

- Fill front wheel-circuit reservoir with brake fluid up to "MAX" mark and install cap, **BMW No. 34 2 541**.
- Connect 1.5 m (4.9214 ft) silicon hose, **BMW No. 34 1 561**, to the bleed screw of the left brake caliper.



Note:

If necessary, use a cable tie to secure the bleed hose to the bleed screw.

- Switch on the ignition.



Note:

After switching on the ignition, always wait for the BMW Integral ABS to complete its self-diagnosis. Do not operate the brake lever until self-diagnosis has completed.

- Very gently pull the handbrake lever until the pump just starts up.
- Open the bleed screw.
- Pump the brake fluid with virtually no pressure until the hose is full of brake fluid.
- Connect end of hose to cap, **BMW No. 34 2 541**.
- Pump the brake fluid with virtually no pressure to begin with, then vary the brake pressure.



Warning:

Check that the brake fluid in the hose does not foam.

If the fluid foams, proceed as described in the section on bleeding and changing brake fluid in front wheel circuit.

(⇒ 00.40)

- Pump brake fluid through the system until it is clear and free from air bubbles.
- Close the bleed screw.
- Release the brake and disconnect silicon hose, **BMW No. 34 1 561**.
- Fill front wheel-circuit reservoir with brake fluid up to "MAX" mark and install cap, **BMW No. 34 2 541**.
- Connect 1.5m (4.9214 ft) silicon hose, **BMW No. 34 1 561**, to the bleed screw of the right brake caliper.
- The procedure for bleeding the right brake caliper is the same as that for the left caliper.
- Release the brake and switch off the ignition.
- Disconnect silicon hose, **BMW No. 34 1 561**, from bleed screw and drain the hose.
- Remove cap, **BMW No. 34 2 541**.



Attention:

After changing and/or bleeding the brakes, always top up the fluid in the wheel-circuit reservoir to the correct level in accordance with the instructions.

- Fill front wheel-circuit reservoir with brake fluid in accordance with instructions. (⇒ 00.42)
- Check operation of the brake system with the ignition switched on.



Attention:

After all the work on the brake system has been completed, run a bleed test using the **BMW MoDiTeC**.

Brake fluidDOT 4



Tightening torque:

Bleed screw in front brake caliper 7 Nm
Grub screw in front brake caliper 7 Nm

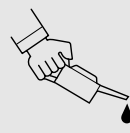

34 00 080 Bleeding/changing brake fluid in rear wheel circuit



Attention:

Integral brakes, the front brake must be ready for use.

- Remove fuel tank.



Attention:

Do not allow brake fluid to come into contact with painted parts of the motorcycle as brake fluid destroys paint.

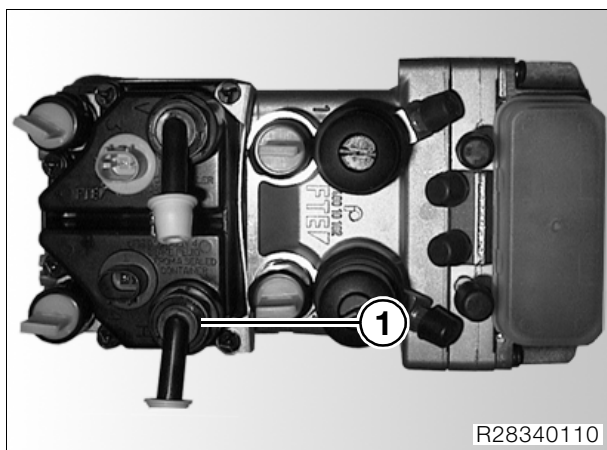

- Open rear wheel-circuit reservoir (1).
- Draw off the old brake fluid from the wheel-circuit reservoir.
- Remove rear brake pads.
- If necessary, manually push back brake piston far enough to permit installation of resetting tool, **BMW No. 34 1 531**.



Attention:

Install piston resetting tool, **BMW No. 34 1 531** only when the cap has been removed from the wheel-circuit reservoir.

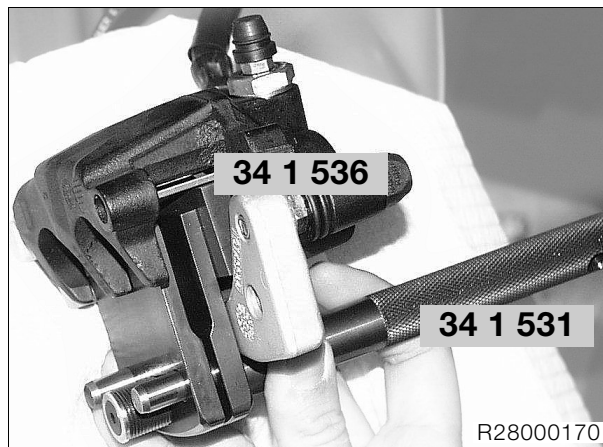

- Install adapter, **BMW No. 34 1 536**, instead of the outboard brake pad.
 - Install resetting tool, **BMW No. 34 1 531**, with the handle toward the outside in the rear brake caliper, press the pistons fully back and secure them in this position.
 - Wrap a cloth around the brake caliper.
- **[Bleeding only]** Bleed the rear wheel circuit. (→ 00.47)
- Draw off the old brake fluid from the wheel-circuit reservoir.

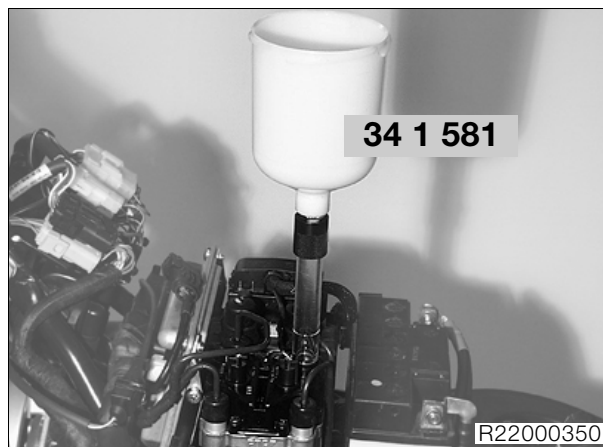

- Screw container, **BMW No. 34 1 581**, onto rear wheel circuit reservoir.
- Slowly fill container, **BMW No. 34 1 581**, with new brake fluid until it is approximately 1/3 full.
- Connect the brake bleeding device to the bleed screw, but **do not switch on** the device.



Note:

If necessary, use a cable tie to secure the bleed hose to the bleed screw.

- Switch on the ignition



Note:

After switching on the ignition, always wait for the BMW Integral ABS to complete its self-diagnosis. Do not operate the brake lever until self-diagnosis has completed.

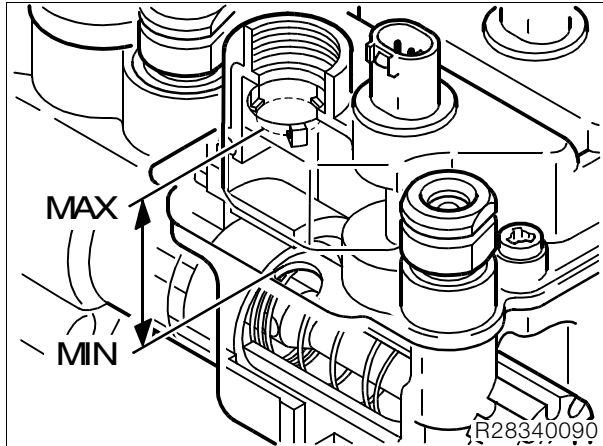

- Close the bleed screw.
- Release the brake and switch off the ignition.
- Disconnect the brake bleeding device from the bleed screw.
- Disconnect the container from the wheel-circuit reservoir.



Attention:

After changing and/or bleeding the brakes, always top up the fluid in the wheel-circuit reservoir to the correct level in accordance with the instructions.

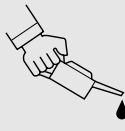

Attention:

The brake fluid must always be visible in the container, because the piston in the base of the wheel-circuit reservoir must always be covered by the fluid. The procedure must be repeated if the fluid drops below the "min" level.

- Very gently press the footbrake lever until the pump just starts up.
- Open the bleed screw, while topping up the container with new brake fluid if necessary.
- Pump out the brake fluid with virtually no pressure to begin with, then vary the brake pressure.



Note:

The higher the brake pressure the faster the fluid is pumped through the system, which means that the level in the wheel-circuit reservoir drops all the more rapidly.

- When the brake fluid is clear and free of bubbles, continue pumping until the fluid in the container just disappears from view.

Instructions for filling rear wheel circuit reservoir

Attention:

Integral brakes, the front brake must be ready for use.

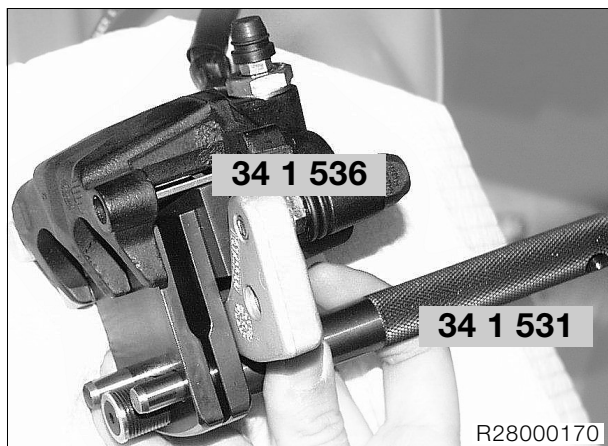

- Top up fluid in rear wheel-circuit reservoir to “MAX” mark if necessary.
- Fully tighten resetting tool, **BMW No. 34 1 531**, and adapter, **BMW No. 34 1 536**.

Attention:

The piston in the base of the wheel-circuit reservoir must always be covered by the fluid, as otherwise air can be drawn into the brake system. Bleed the system again if this happens.

- Switch on the ignition.



Note:

After switching on the ignition, always wait for the BMW Integral ABS to complete its self-diagnosis. Do not operate the brake lever until self-diagnosis has completed.

- Operate the footbrake lever until the pistons of the rear brake caliper are in contact with resetting tool, **BMW No. 34 1 531**, and adapter, **BMW No. 34 1 536**.

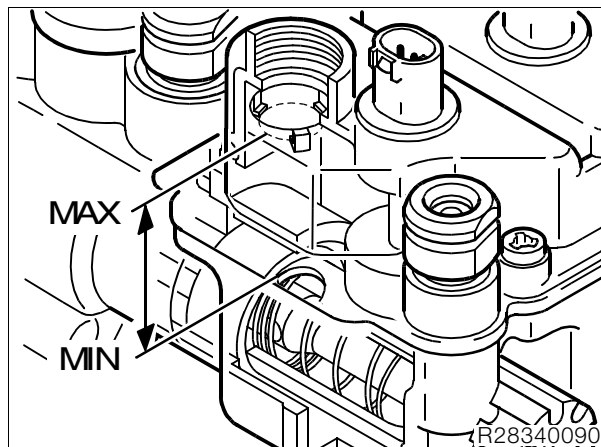

- Top up the fluid in the wheel-circuit reservoir until one of the three protrusions in the filler neck just touches the surface of the fluid (arrow).
- Remove resetting tool, **BMW No. 34 1 531**, and adapter, **BMW No. 34 1 536**.



Warning:

Make sure that the wheel-circuit reservoir does not overflow when the brake pads/brake calipers are installed.

- Install rear brake pads and brake caliper.
- Disconnect the container from the wheel-circuit reservoir.
- Hand-tighten cap of rear wheel-circuit reservoir.
- Check operation of the brake system with the ignition switched on.



Attention:

After all the work on the brake system has been completed, run a bleed test using the **BMW MoDiTeC**.

- Perform bleed test with **BMW MoDiTeC**.
(→ 00.29)
- Install fuel tank.

Brake fluidDOT 4



Tightening torque:

Bleed screw in rear brake caliper 5 Nm
Brake caliper to rear wheel drive 40 Nm

Only bleeding the rear wheel circuit

- Draw off the old brake fluid from the wheel-circuit reservoir.
- Remove rear brake pads, force back the brake pistons and secure the pistons in this position.
- Wrap a cloth around the rear brake caliper.

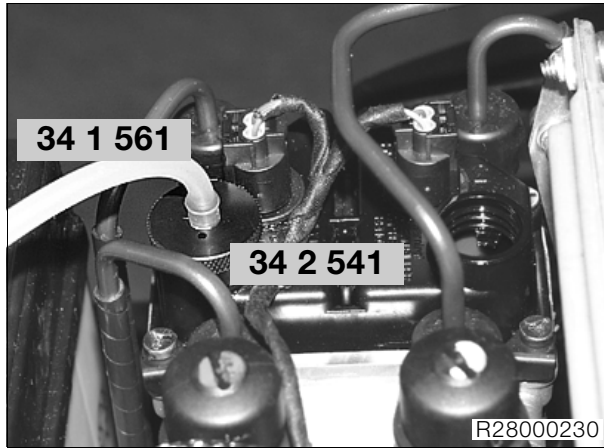

- Fill rear wheel-circuit reservoir with brake fluid up to "MAX" mark and install cap, **BMW No. 34 2 541**.
- Connect 1.5m (4.9214 ft) silicon hose, **BMW No. 34 1 561**, to the bleed screw.



Note:

If necessary, use a cable tie to secure the bleed hose to the bleed screw.

- Switch on the ignition.



Note:

After switching on the ignition, always wait for the BMW Integral ABS to complete its self-diagnosis. Do not operate the brake lever until self-diagnosis has completed.

- Very gently press the footbrake lever until the pump just starts up.
- Open the bleed screw.
- Pump the brake fluid with virtually no pressure until the hose is full of brake fluid.
- Connect end of hose to cap, **BMW No. 34 2 541**.
- Pump the brake fluid with virtually no pressure to begin with, then vary the brake pressure.



Warning:

Check that the brake fluid in the hose does not foam.

If the fluid foams, proceed as described in the section on bleeding and changing brake fluid in rear wheel circuit. (→ 00.44)

- Pump brake fluid through the system until it is clear and free from air bubbles.
- Close the bleed screw.
- Release the brake and switch off the ignition.
- Disconnect silicon hose, **BMW No. 34 1 561**, from bleed screw and drain the hose.
- Remove cap, **BMW No. 34 2 541**.



Attention:

After changing and/or bleeding the brakes, always top up the fluid in the wheel-circuit reservoir to the correct level in accordance with the instructions.

- Fill rear wheel-circuit reservoir with brake fluid in accordance with instructions. (→ 00.46)
- Check operation of the brake system with the ignition switched on.



Attention:

After all the work on the brake system has been completed, run a bleed test using the **BMW MoDiTeC**.

Brake fluidDOT 4



Tightening torque:

Bleed screw in rear brake caliper 6 Nm
 Brake caliper to rear wheel drive 40 Nm



34 00 091 Changing/bleeding brake fluid in control circuit

Change brake fluid in control circuit every 2 years
(Inspection IV)



Warning:

All repair and maintenance work on the BMW Integral ABS must be performed by trained, qualified specialists. Comply with all maintenance and repair instructions and always work through the various steps in the correct order. Use only new brake fluid from freshly opened containers.

34 00 072 Bleeding/changing brake fluid in front control circuit



Warning:

When performing maintenance and repair work on BMW Integral ABS, never pump quickly or vigorously.

- Place the motorcycle on its side stand and turn the handlebars all the way to the left.
- Repeatedly and slowly pull front brake lever lightly to expel air from brake master cylinder.
- Place the motorcycle on its main stand.
- Remove fuel tank.
- Turn the front wheel to a position in which the brake fluid reservoir is horizontal and secure the handlebars in this position.



Attention:

Do not allow brake fluid to come into contact with painted parts of the motorcycle as brake fluid destroys paint.

- Wrap cloths around the reservoir.
- Remove front reservoir cap with rubber diaphragm, draw off the old brake fluid and clean the reservoir.

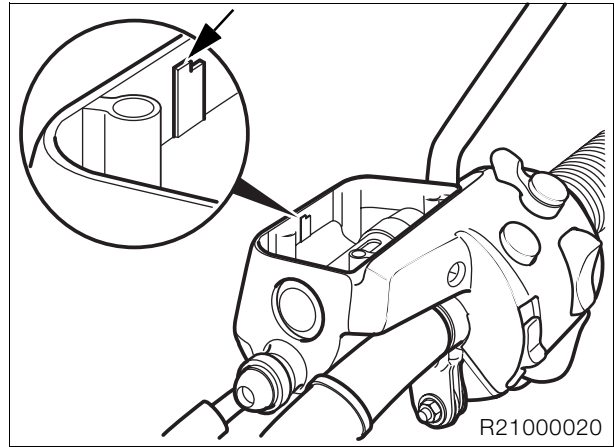

- Top up the brake fluid level to the "MAX" mark (arrow).

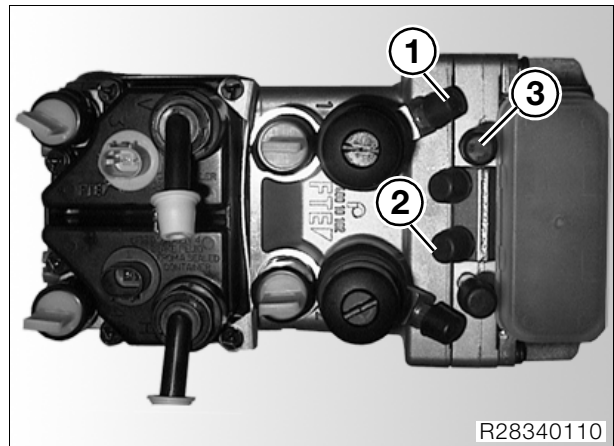

- Connect the brake bleeding device to bleed screw (1) of the front metering cylinder, but **do not switch on**.



Warning:

Do not use vacuum extraction to change the brake fluid in the control circuits or bleed the control circuits.

⚠ Attention:

During the fluid-change and bleeding procedure, make sure that the fluid replenishing hole is always below the level of the brake fluid, or else air will be drawn into the brake system. Bleed the system again if this happens.

- Set the handbrake lever to position 4.

🚫 Warning:

When performing maintenance and repair work on BMW Integral ABS, never pump quickly or vigorously.

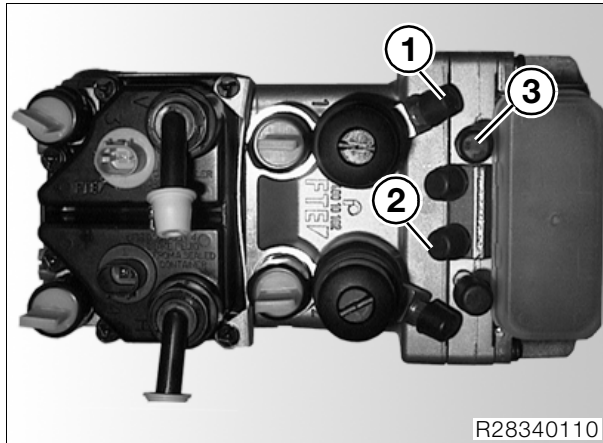

- In the following sequence, bleed:
 - front metering cylinder (1),
 - front integral circuit (2)
 - front control circuit (3) and
 - front metering cylinder (1) for the second time using ring spanner, **BMW No. 34 2 532**, in accordance with instructions for bleeding.

Instructions for bleeding:

1. Slowly pull brake lever until brake-light switch clicks (blow-by bore closed).
2. Open the bleed screw.
3. Slowly pull brake lever to full extent of its travel and close the bleed screw.
4. Slowly release the brake lever.
5. Repeat steps 1 to 4 until the brake fluid is clear and free of bubbles.

- Fit the protective caps on the bleed screws.
- Top up the brake fluid until the level reaches the “MAX” mark.
- Wipe the rim of the reservoir, the rubber diaphragm and the cover to remove brake fluid, and carefully reassemble the components.

- Recheck the brake-fluid level.
- Place the motorcycle on its centre stand.
- Turn the handlebars to the **left**.

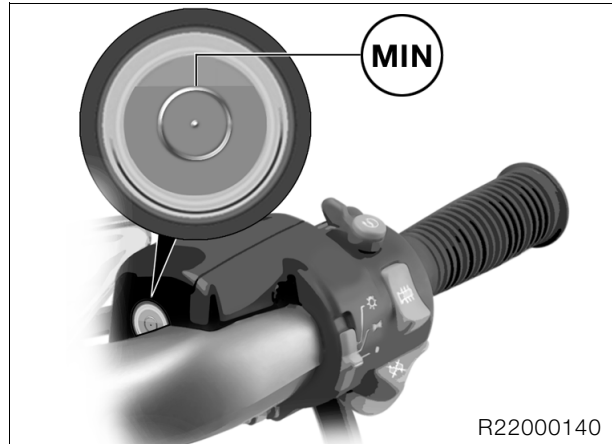

Required level

not below MIN
(top edge of the marking ring)

⚠ Attention:

After all the work on the brake system has been completed, run a bleed test using the **BMW MoDiTeC**.

Brake fluidDOT 4

34 00 082 Bleeding/changing brake fluid in rear control circuit

- Place the motorcycle on its main (centre) stand.
- Fuel tank removed.



Attention:

Do not allow brake fluid to come into contact with painted parts of the motorcycle as brake fluid destroys paint.

- Remove right case, if necessary.
- Remove small right side fairing panel.
- Remove rear reservoir cap with rubber diaphragm, draw off the old brake fluid and clean the reservoir.

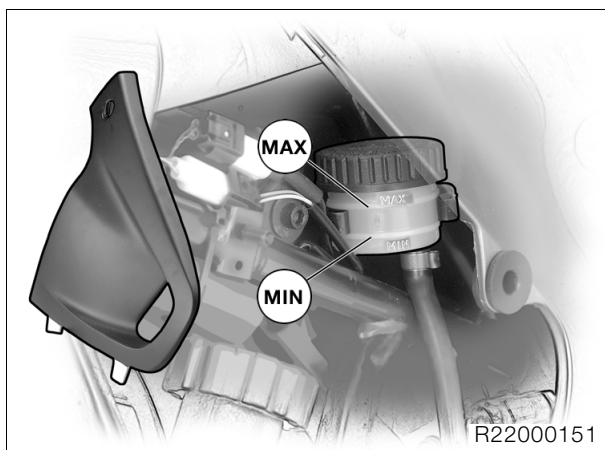

- Top up the brake fluid level to the "MAX" mark.
- Connect the brake bleeding device to bleed screw (1) of the rear metering cylinder, but **do not switch on**.



Warning:

Do not use vacuum extraction to change the brake fluid in the control circuits or bleed the control circuits.



Attention:

While bleeding the system, do not allow the brake fluid level to drop below the "MIN" mark, as otherwise air will be drawn into the brake system. Bleed the system again if this happens.



Warning:

When performing maintenance and repair work on BMW Integral ABS, never pump quickly or vigorously.

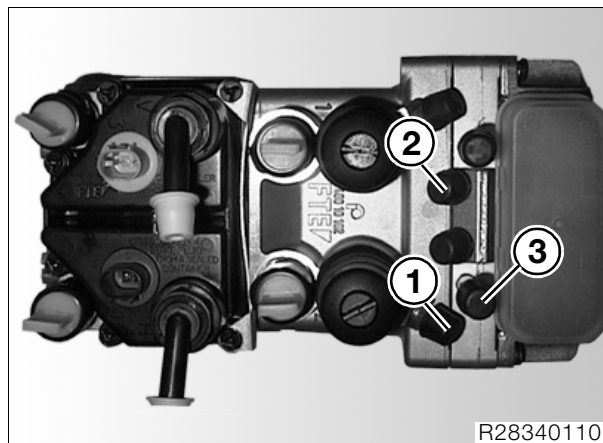

- In the following sequence, bleed:
 - rear metering cylinder (1),
 - rear integral circuit (2),
 - rear control circuit (3) and
 - rear metering cylinder (1) for the second time using ring spanner, **BMW No. 34 2 532**, in accordance with instructions for bleeding.

Instructions for bleeding:

1. Slowly depress brake lever until brake-light switch clicks (blow-by bore closed).
2. Open the bleed screw.
3. Slowly depress brake lever to full extent of its travel and close the bleed screw.
4. Slowly release the brake lever.
5. Repeat steps 1 to 4 until the brake fluid is clear and free of bubbles.

- Fit the protective caps on the bleed screws.

- Correct the brake fluid level.
- Wipe the rim of the reservoir, the rubber diaphragm and the cover to remove brake fluid, and carefully reassemble the components.
- Place the motorcycle on its centre stand.

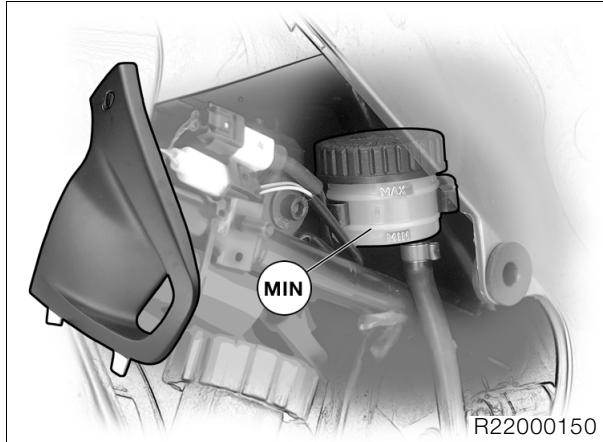

Required level
not below MIN



Attention:
After all the work on the brake system has been completed, run a bleed test using the **BMW MoDiTeC**.

- Perform bleed test with **BMW MoDiTeC**.
(→ 00.29)
- Install fuel tank.

Brake fluid DOT 4

Checking clutch operating fluid level

(Inspections II and III)



Attention:

Keep the brake fluid in the clutch operating system away from painted surfaces on the motorcycle because brake fluid attacks paint.

- Place motorcycle on its **centre stand**.
- Move the handlebars to the **straight-ahead position**.

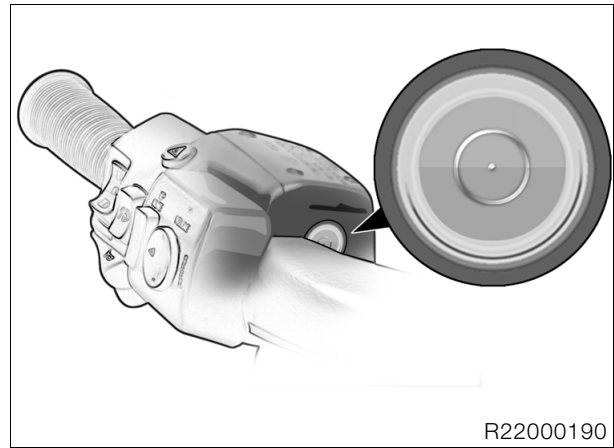
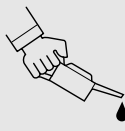

Required level with a new clutch liner:
..... Half way up sight glass



Note:

As the clutch lining wears, the fluid level in the reservoir rises.

- If necessary, remove reservoir cap with insert.
- Correct the fluid level.
- Mark in reservoir: same as brake circuit.
- Reinstall the reservoir cap with insert.
- Tighten the reservoir cap carefully and without using force.

Brake fluid DOT 4

21 52 005 Changing the clutch fluid

(Inspection IV)
every 2 years at the latest



Note:

The description applies to a brake system filling and bleeding device with vacuum extraction of brake fluid at the bleed line.

If other devices are used, comply with their manufacturers' instructions.

- Place the motorcycle on its main (centre) stand.
- Turn the handlebars to a position in which the clutch fluid reservoir is horizontal.
- Secure front wheel in position.



Attention:

Keep the brake fluid in the clutch operating system away from painted surfaces on the motorcycle because brake fluid attacks paint.

- Remove reservoir cap with rubber diaphragm.
- Draw off the brake fluid and clean the reservoir.
- Top up the brake fluid.

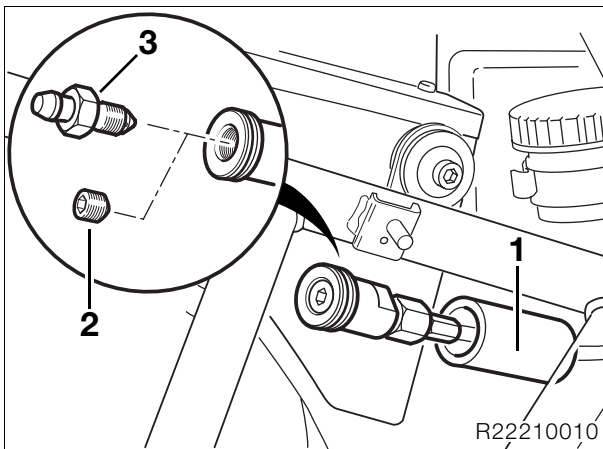

- Pull back protective hose (1).
- Wrap a cloth around the filler adapter.
- Remove socket-head grub screw (2) from the filler adapter.
- Connect the brake bleeding device to bleed screw (3).

- Screw the bleed screw all the way into the filler adapter (valve in filler adapter closed).



Attention:

While bleeding the system, do not allow the brake fluid level to drop below the bottom edge of the ring mark, as otherwise air will be drawn into the clutch system. Bleed the system again if this happens.

- Open the bleed screw by half a turn (valve open).
- Draw off brake fluid until it emerges clear and free from air bubbles.
- Remove the bleed screw.
- Disconnect the brake bleeding device from the bleed screw.



Note:

On account of the vacuum extraction process, it might not be possible to tell whether there is brake fluid in the hose of the brake bleeding device when it is free of bubbles.

In this case bleed the system manually.

- Reinstall socket-head grub screw (2) in the filler adapter.



Attention:

The motorcycle is not permitted on the road without the grub screw in place and secure in the filler adapter.

- Correct the fluid level.
- Reinstall the reservoir lid with rubber diaphragm in position.
- Tighten the reservoir cap carefully and without using force.
- Recheck the fluid level.



Tightening torque:

Grubscrew in filler adapter 10 Nm

Consumables

Brake fluid.....DOT 4

Checking tightness of rear wheel studs

(Inspection I)

- Tighten the rear wheel studs with a torque wrench.



Tightening torque:

Securing screws for rear wheel 105 Nm

Checking rear wheel bearing play by tilting wheel

(Inspection III)

- Tilt the rear wheel to and fro across its axle.
 - If play is detected, fit new shims to rear wheel drive or replace bearings.

➡ see Group 33

Checking swinging arm bearings, adjusting if necessary

(Inspections I and III)

- Grip rear tyre and try to move it sideways, bracing against the frame.
 - If play is perceptible, remove fixed-bearing stud and floating-bearing stud of the bearing in question, clean the threads and reinstall.

➡ see Group 33

Greasing the side stand pivot

(Inspections I, II and III)

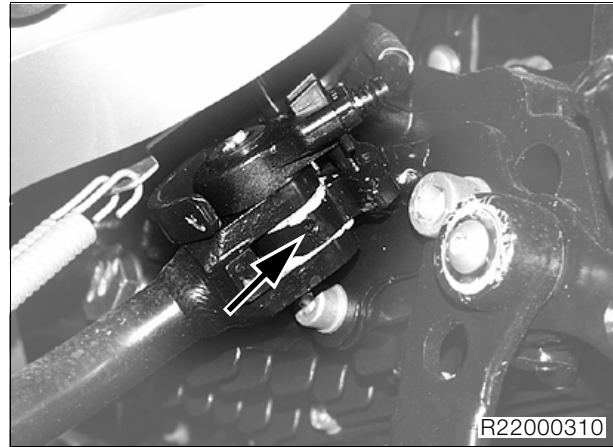

- Check free movement of side stand and grease if necessary.
- Grease pivot point (arrow).

Lubricant:

..... Shell Retinax EP2

Checking function of side stand contact switch

(Inspections I, II, III and IV)

- Place the motorcycle on its centre stand.
- Retract the side stand, if extended.
- Disengage the clutch and select a gear.
- Start the engine, without releasing the clutch lever.
- Extend the side stand.



Note:

The side-stand switch is in correct working order if the engine stops when the side stand is extended.

12 12 011 Checking/replacing spark plugs

(Inspection II) check/(Inspection III) replace

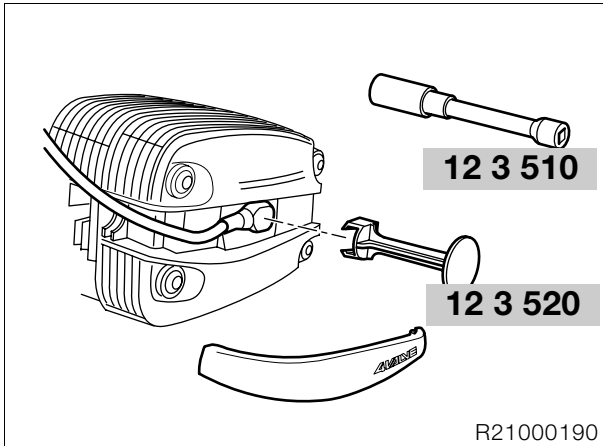

- Pull off spark plug caps with special puller, **BMW No. 12 3 520**.
- Remove spark plugs with the spark plug wrench, **BMW No. 12 3 510**.

⚠ Attention:
Do not bend electrodes - risk of breakage!

Spark plug:.....NGK BKR 7 EKC
Electrode gap: 0.8 mm (0.0314 in)
Wear limit: 1.0 mm (0.0393 in)

⚠ Tightening torque:
Spark plug NGK BKR7EKC 25 Nm

11 12 009 Tightening cylinder heads

(Inspection I)

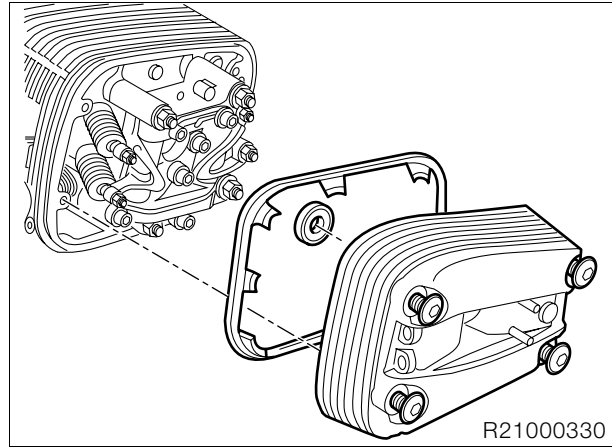

- Remove cylinder head cover.

⚠ Attention:
Catch escaping oil.

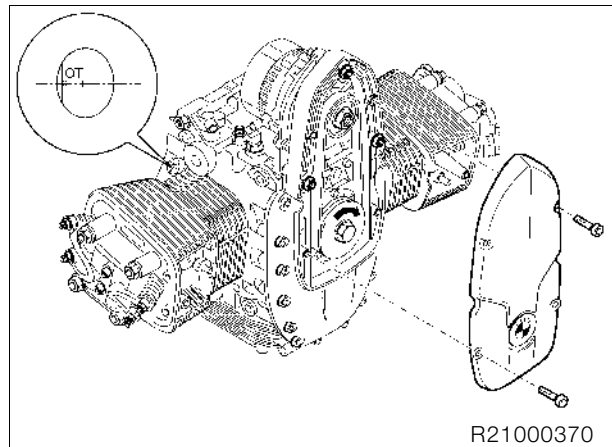

- Select a gear and turn the rear wheel, or set the piston to TDC on the ignition stroke by turning the belt pulley.

Top dead centre on ignition stroke:

- The TDC mark is visible and the inlet and exhaust valves in the cylinder concerned are closed.
- Tighten cylinder head nuts.

Tightening procedure after 1,000 km (600 miles)

1. Tighten the cylinder head nuts one after the other in diagonally opposite sequence
 - 1.1. Slacken off one nut at a time
 - 1.2. Tighten nut to initial torque..... 20 Nm
 - 1.3. Tighten nut to specified wrench angle..... 180°
2. Slacken/retighten M10 screw..... 40 Nm

11 34 004 Checking/adjusting valve clearances

(Inspections I, II and III)

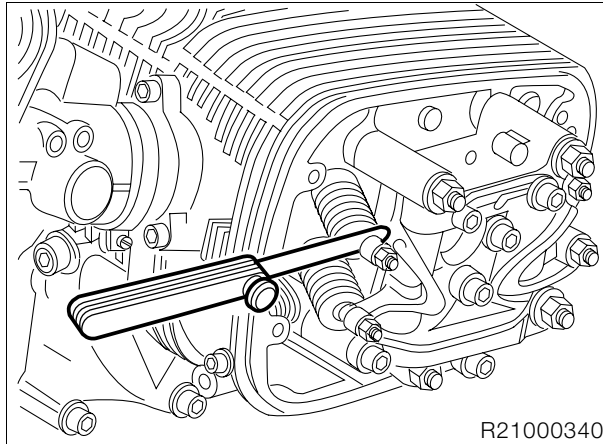

- Check valve clearance with feeler gauge and, if necessary, correct with adjusting screw.

Valve clearances with engine cold (max. 35 °C/95 °F):

Inlet 0.15 mm (0.0059 in)
 Exhaust 0.30 mm (0.0118 in)

 **Tightening torque:**
 Locknut 8 Nm

- Recheck valve clearances after adjusting. Feeler gauge must pull through between valve stem and adjusting screw with slight resistance.
- Assembly is the reverse of the disassembly procedure.

Attention:

Make sure that all seals are correctly seated. Seals and sealing faces must be free from oil and grease.

 **Tightening torque:**
 Cylinder head cover 8 Nm

13 60 110 Checking freedom of throttle cable, checking for chaffing and kinks, replacing if necessary Checking throttle-cable play Checking and adjusting idle speed and throttle-valve synchronisation

(Inspections I, II and III)

- Test-drive the motorcycle until the engine is warm.
- Remove the left side panel.
- Remove the flap in the right side panel.

Oil temperature:at least 90 °C (194 °F)

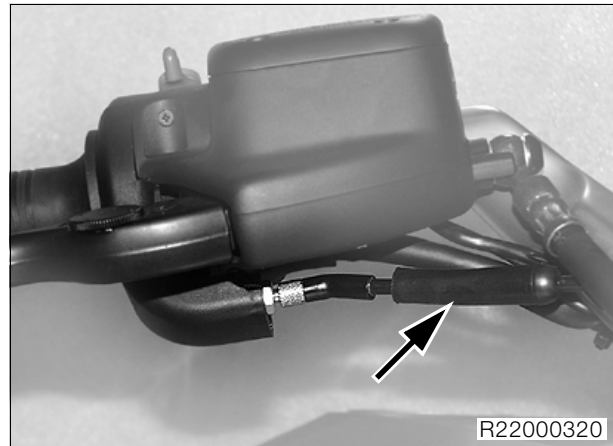

- Push back rubber cap (arrow) on throttle and choke cables.
- Use the adjusting screws to adjust play of throttle and choke cables.

Play of choke cable:approx. 1 mm (0.0393 in)
Play of throttle cable:approx. 1 mm (0.0393 in)



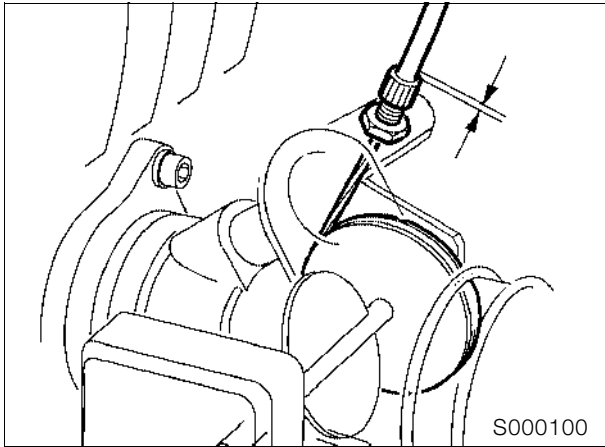

- Turn the adjusting screws to adjust the play of the cables for the left and right throttle valves.

Play of throttle cable: approx. 2 mm (0.0787 in)

- Connect hose of **BMW** Synchro to vacuum adapter and connect cables to **BMW** MoDiTeC.
- Start the engine.

⚠ Attention:

Do not allow the engine to idle for longer than is necessary, because the trim panels near the exhaust could be damaged.

- Adjust idle speed by turning the air bypass screws while checking that the carburetors are balanced.

Idle speed: 1,100 ±50 rpm

📄 Note:

Make sure that both throttle valves are closed.

⚠ Attention:

Do not tamper with the sealed stop screws of the throttle valves, as otherwise the idle-speed volume flow will have to be reset by the manufacturer.

- Carefully turn the adjusting screw of the left throttle valve and reduce play until the reading of the Synchro tester changes.
- Turn the adjusting screw very slightly in the opposite direction until the reading returns to its original value.
- Tighten the locknut to secure.

📄 Note:

Make sure that the reading does not change when you tighten the locknut.
Adjust throttle cable play at throttle valve so that no play is perceptible, but the throttle valve reliably contacts the stop screw (no strain on cable).

- Adjust the right throttle valve in the same way.

📄 Note:

Zero play can cause the throttle valves to rattle.

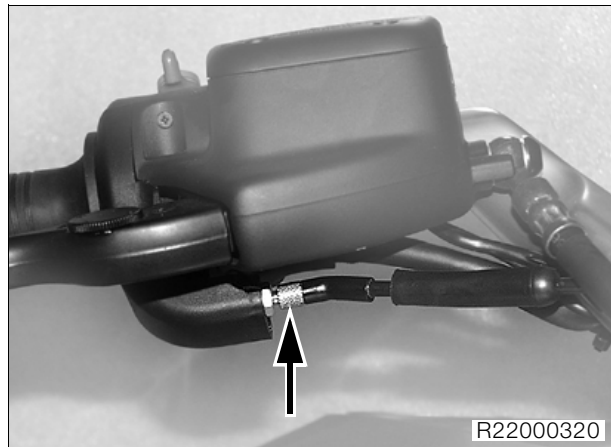

- Use the adjusting screws (arrow) to adjust play of the throttle cables.

Play of throttle cable:

.....approx. 0.5 mm (0.0197 in)

- Push the rubber cap into position over the adjusting screw.

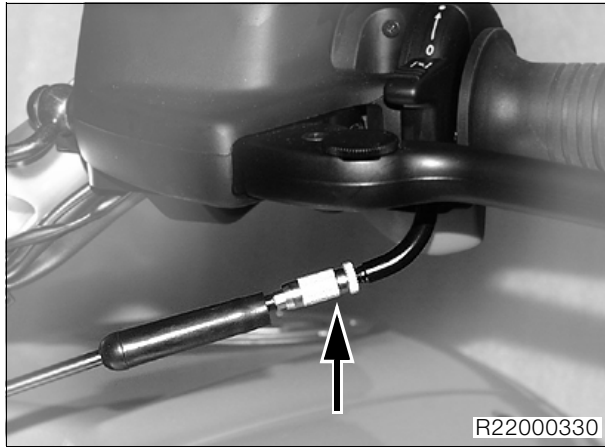

- Use the adjusting screw (arrow) to adjust play of the choke cable to zero.
- Push the rubber cap into position over the adjusting screw.
- Move the handlebars all the way from left to right and check the settings. Make sure that engine speed does not vary when the handlebars are moved in this way.
- Repeatedly open the throttle gradually and increase engine speed from idle to approximately $n = 2,500$ rpm to check throttle-valve synchronisation. (Readings shown by Synchro tester must increase and decrease together). If necessary, correct by turning the adjusting screws of the throttle-valve Bowden cable.



Note:

Make sure that when the throttle grip is released both throttle valves return to their fully closed positions.

- Tighten the locknuts and recheck carburettor balance.
- Seal off the vacuum bores.
- Assembly is the reverse of the disassembly procedure.

Final inspection with road safety and functional check

(Inspections I, II, III and IV)

Road safety check

- Check wheels and tyres.
- Check/correct tyre pressures.
- Wait at least 10 minutes after heating the engine to operating temperature in the trial run/road test before checking/correcting engine oil level.



Tyre pressures:

one-up	front 2.2 bar (31.90 psi)
.....	rear 2.5 bar (36.26 psi)
two-up	front 2.5 bar (36.26 psi)
.....	rear 2.9 bar (42.06 psi)
two-up + luggage	front 2.5 bar (36.26 psi)
.....	rear 2.9 bar (42.06 psi)

Roadworthiness check

- Lights
- Telltale/warning lights
- Horn
- Instruments
- Special equipment
- Clutch
- Gear shift
- Steering
- Footbrake and handbrake, Integral ABS
- If necessary, take the motorcycle for a test ride.



34 Brakes

Contents

Page

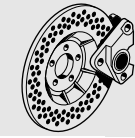

Technical Data 34 Brakes	3
Removing and installing front brake caliper	4
Disassembling and assembling front brake caliper	5
Removing and installing rear brake caliper	6
Disassembling and assembling rear brake caliper	7
Disassembling rear brake caliper	7
Assembling rear brake caliper	7
Removing and installing front brake discs	8
Removing and installing rear brake disc	8
Removing and installing Integral ABS sensor	9
Removing and installing front Integral ABS sensor	9
Removing and installing rear Integral ABS sensor	10
Removing and installing footbrake lever	11
Removing and installing rear brake master cylinder	11
Checking and adjusting blow-by clearance of piston rod	12
Checking blow-by clearance of piston rod	12
Adjusting blow-by clearance at piston rod	12
Checking and adjusting setting of rear brake light switch	13
Checking setting of brake light switch, rear	13
Adjusting brake light switch, rear	13
Removing and installing piston in brake-lever fitting	13
Removing and installing Integral ABS pressure modulator	14
Removing Integral ABS pressure modulator	14
Installing Integral ABS pressure modulator	15

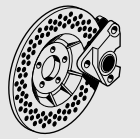

Draining the Integral ABS brake system	16
Drain both wheel circuits	16
Draining front wheel circuit	16
Draining rear wheel circuit	17
Draining control circuits	18
Draining front control circuit	18
Draining rear control circuit	18
Filling and bleeding Integral ABS system	19
Filling and bleeding control circuits	19
Filling the front control circuit	19
Bleeding front control circuit	20
Filling the rear control circuit	21
Bleeding the rear control circuit	21
Filling and bleeding wheel circuits	23
Filling and bleeding front wheel circuit	23
Instructions for filling front wheel circuit reservoir	25
Filling and bleeding rear wheel circuit	26
Instructions for filling rear wheel circuit reservoir	28
Integral ABS	
Reading fault memory with BMW MoDiTeC	29
Integral ABS	
Performing bleed test with BMW MoDiTeC	29
Integral ABS	
Removing and installing bleed lines, wheel circuit reservoirs	30
Integral ABS: Removing and installing brake lines	31
Installed position of front brake line	32
Installed position of rear brake line	33

Technical Data 34 Brakes		R 1150 RT
Brake fluid		DOT 4
Front wheel		
Type		Hydraulically operated twin disc brake with 4-piston fixed calipers and floating brake discs
Colour of identification mark on brake calipers/brake pads		white
Brake pad lining		Sintered metal
Minimum lining thickness	mm (in)	1.0 (0.0393 in)
Brake pad surface area	cm ² (sq in)	86 (13.33)
Brake disc dia.	mm (in)	320 (12.5987)
Brake disc thickness	mm (in)	5.0 (0.1969)
Minimum thickness of brake discs	mm (in)	4.5 (0.1772)
Permissible lateral runout	mm (in)	0.15 (0.0059)
Piston dia. in brake caliper	mm (in)	32/36 (1.2599/1.4173)
Piston dia. in handlebar lever cylinder	mm (in)	16 (0.6299)
Rear wheel		
Type		Hydraulically operated disc brake with 2-piston floating caliper and fixed disc
Brake pad lining		Sintered metal
Minimum lining thickness	mm (in)	1.0 (0.0393) (If the brake disc is visible through the bore in the wheel-side brake pad, the brake lining is worn to its minimum permissible thickness)
Brake pad surface area	cm ² (sq in)	33.8 (5.23)
Brake disc dia.	mm (in)	276 (10.8661)
Brake disc thickness	mm (in)	5.0 (0.1968)
Minimum thickness of brake disc	mm (in)	4.5 (0.1772)
Permissible lateral runout	mm (in)	0.15 (0.0059)
Piston dia. in brake caliper	mm (in)	26/28 (1.0236/1.1023)
Piston dia. in actuating cylinder	mm (in)	13 (0.5118)
BMW Integral ABS		
Type		Active fully integral system
Sensor gap, front	mm (in)	0.2...1.7 (0.0079...0.0670) (active sensor)
Sensor gap, rear	mm (in)	0.2...1.7 (0.0079...0.0670) (active sensor)

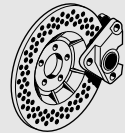

34 11 Removing and installing front brake caliper



Attention:

Do not allow brake fluid to come into contact with painted parts of the motorcycle as brake fluid destroys paint.

- **Integral ABS** Drain front wheel circuit (→ 34.16).

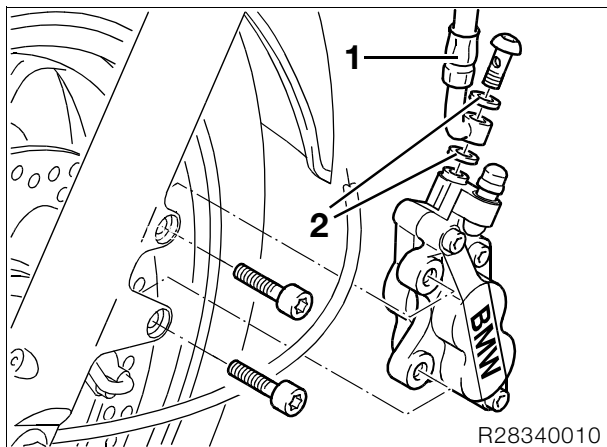

- Disconnect brake line (1).
- Remove the brake caliper securing screws.
- Carefully remove the brake caliper.



Attention:

Replace the sealing rings (2) in the brake line. Do not damage the brake pads when installing.

- Installation is the reverse of the removal procedure.
- **Integral ABS** Fill and bleed front wheel circuit (→ 34.23).



Tightening torque:

Brake caliper to fork slider..... 30 Nm
Brake hose to brake caliper 18 Nm
Bleed screw to brake caliper 7 Nm
Grub screw in front brake caliper 7 Nm

Colour code:

Brake pads/brake calipers white

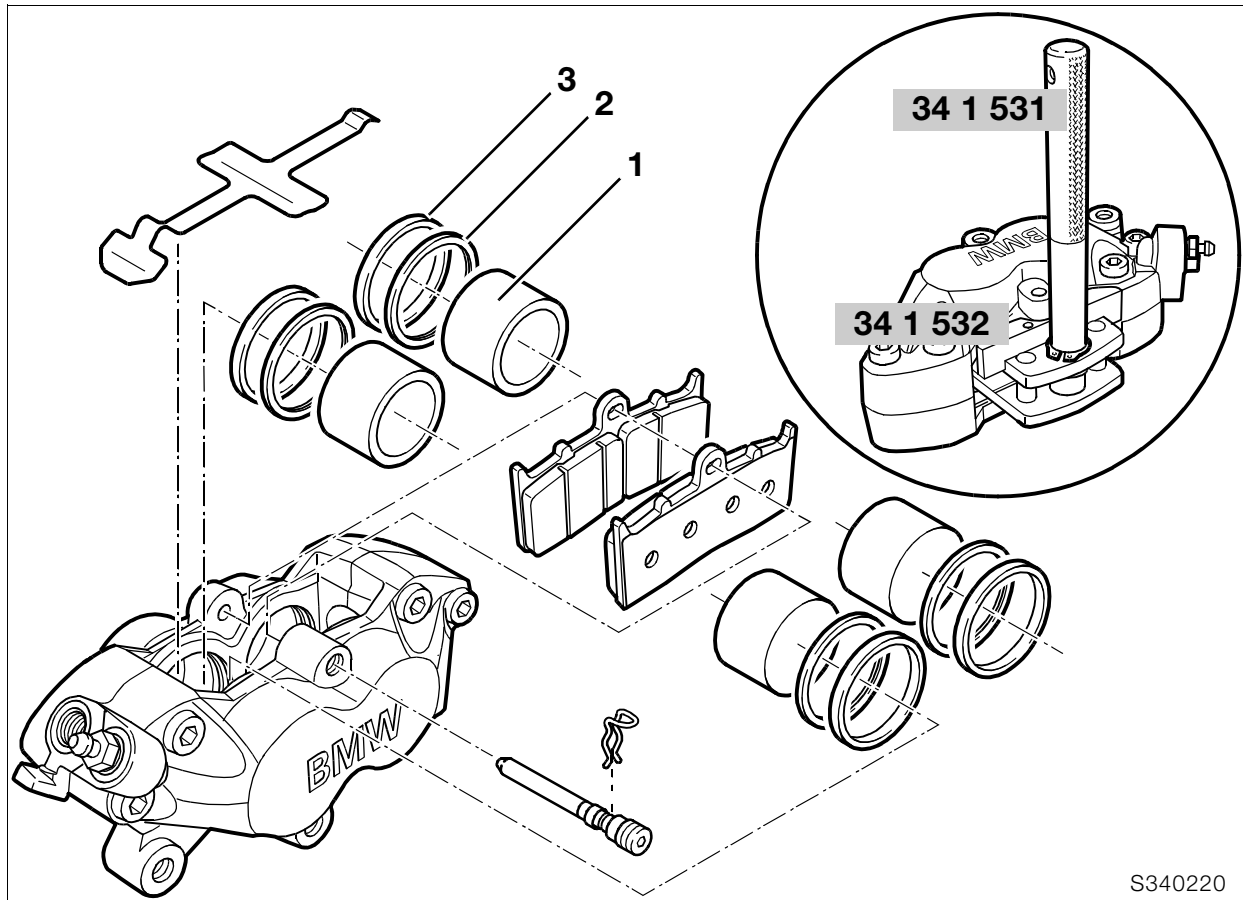

S340220

34 11 521 Disassembling and assembling front brake caliper

⚠ Attention:

Do not separate the brake caliper halves!

- **Integral ABS** Drain front wheel circuit (→ 34.16).
- Remove the brake caliper.
- Remove the brake pads.
- Close the bleed screw.
- Secure two opposing brake pistons with spacer, **BMW No. 34 1 520**.
- Insert a piece of cloth between the two brake pistons not secured by the resetting tool.

⚠ Attention:

Do not insert your fingers between the pistons; risk of injury.

- **Carefully** press out brake pistons (1), using a compressed air gun at the brake line connection.
- Remove the two sealing rings from each brake cylinder bore.
- Inspect the brake caliper piston for hairline cracks, score-marks and other damage.
- Coat new sealing rings (2, 3) with brake fluid and install.
- Coat brake caliper pistons (1) with brake fluid and insert.

⚠ Attention:

Keep the brake pistons parallel with their bores when installing.

- Remove and install the other two brake pistons in the same way.
- Using piston resetting tool, **BMW No. 34 1 531**, press the pistons fully back.
- Install brake caliper.
- **Integral ABS** Fill and bleed front wheel circuit (→ 34.23).

🔧 Tightening torque:

Bleed screw to brake caliper 7 Nm
Grub screw in front brake caliper 7 Nm

Colour code:

Brake pads/brake caliperswhite

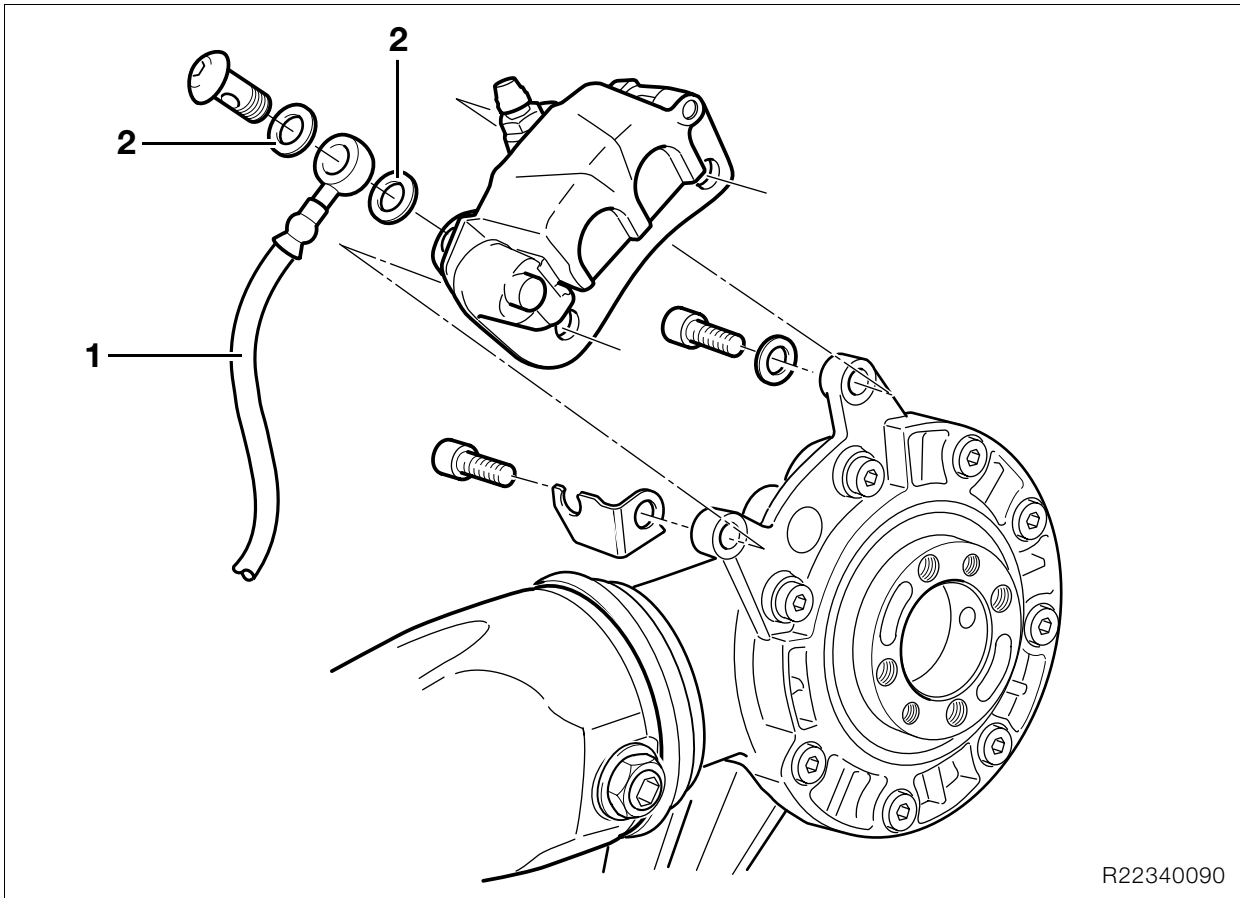
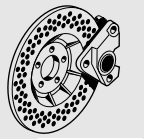

34 21 Removing and installing rear brake caliper

Attention:

Do not allow brake fluid to come into contact with painted parts of the motorcycle as brake fluid destroys paint.

- **Integral ABS** Drain rear wheel circuit (→ 34.17).
- Disconnect brake line (1) from brake caliper.
- Remove the brake caliper.

Attention:

Replace the sealing rings (2) in the brake line. Do not damage the brake pads.

- Installation is the reverse of the removal procedure.

Note:

To bleed, position the brake caliper with the bleed nipple at the highest point.

- **Integral ABS** Fill and bleed rear wheel circuit (→ 34.26).



Tightening torque:

Brake caliper to rear wheel drive	40 Nm
Brake hose to brake caliper	18 Nm
Bleed screw to brake caliper	5 Nm

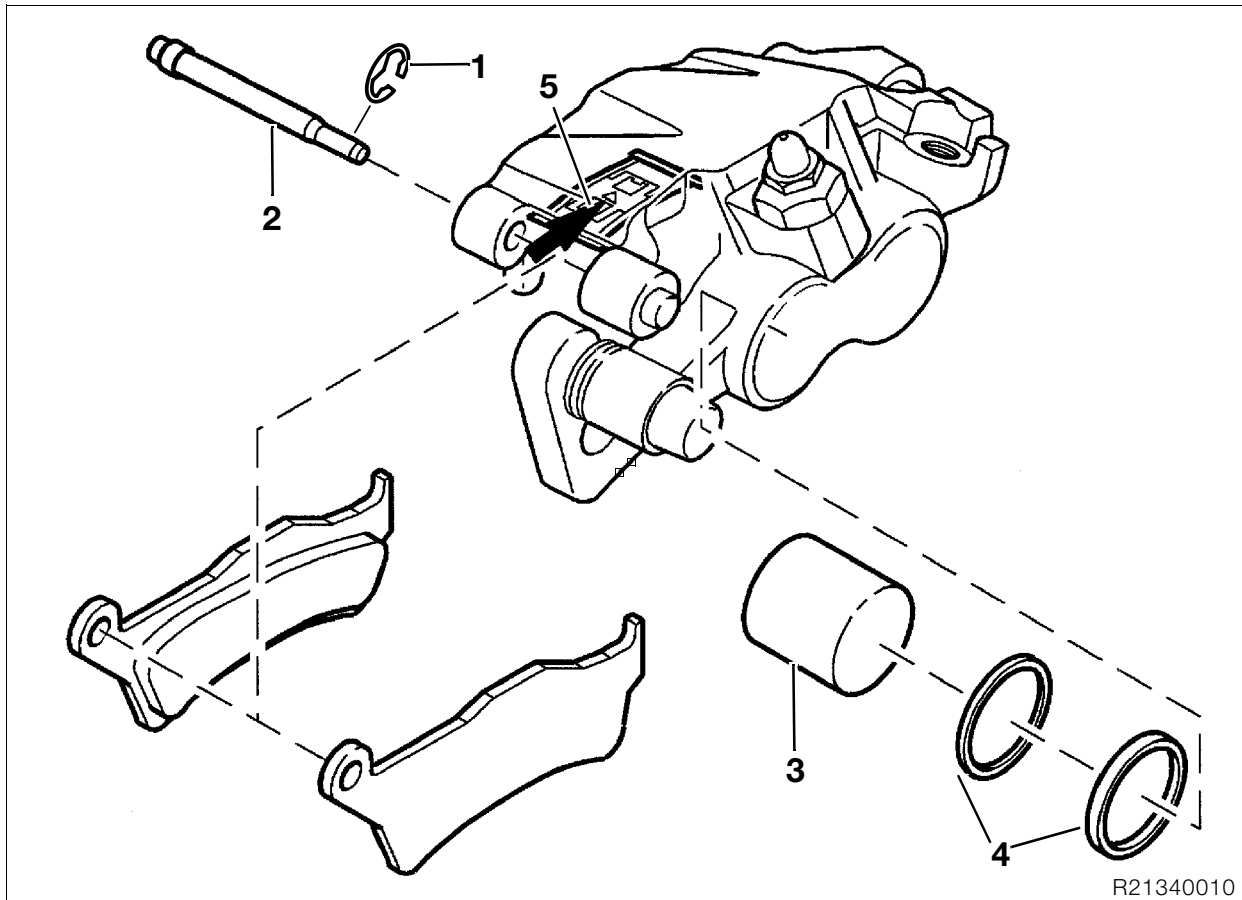

34 21 Disassembling and assembling rear brake caliper

Disassembling rear brake caliper

- **Integral ABS** Drain rear wheel circuit (→ 34.17).
 - Remove the brake caliper.
- Close the bleed screw.
 - Hold a cloth over the brake caliper piston.
 - **Carefully** press out brake piston (3) with a compressed air gun applied to the connecting bore; work at low air pressure.

Attention:

Keep fingers away from gap between piston and side contact face of brake pads; risk of injury.

- Remove sealing rings (4) from left and right bores.
- Inspect the brake caliper piston for hairline cracks, score-marks and other damage.

Tightening torque:

Bleed screw to brake caliper 5 Nm

Assembling rear brake caliper

- Coat the new sealing rings with brake fluid and insert them into the left and right brake caliper bores.
- Coat both brake caliper pistons with brake fluid and install them.

Attention:

Keep the brake pistons parallel with their bores when installing.

- Coat the adapter plate locating pins with **Shell Retinax A** and install the adapter plate.
- Insert locating plate (5) into brake caliper.

Note:

The installed position must be correct (arrow pointing in forward-travel direction).

- Using piston resetting tool, **BMW No. 34 1 531**, press the pistons fully back.
- **Integral ABS** Fill and bleed rear wheel circuit (→ 34.26).

Tightening torque:

Brake caliper to rear wheel drive 40 Nm
 Brake hose to brake caliper 18 Nm
 Bleed screw to brake caliper 5 Nm

34 11 Removing and installing front brake discs



Warning:

When removing and installing the brake calipers, force back the pistons carefully to ensure that the wheel-circuit reservoir does not overflow. If fluid escapes, proceed in accordance with “instructions for filling reservoir” (→ 34.25).

- Remove the brake calipers.
- Remove front wheel.

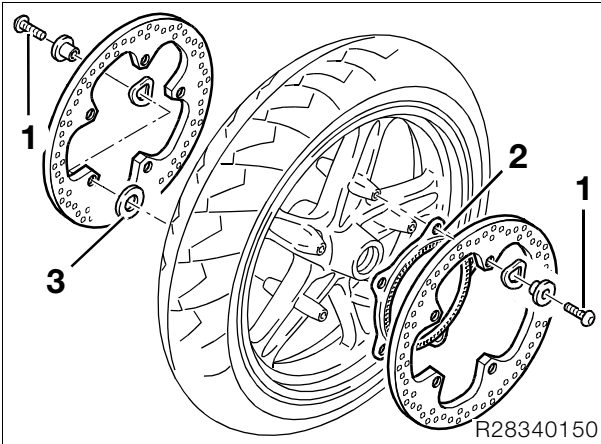

Note:

Retaining screws (1) are secured with thread-locking compound and should be heated if necessary before removal.

- Remove brake discs.



Attention:

Note thrust washers between right brake disc and front wheel, and note ABS sensor ring between left brake disc and front wheel.

- Install ABS sensor ring (2) on left and thrust washers (3) on right beneath brake disc.
- Degrease brake discs before installing.



Attention:

Install brake discs right way round (inscriptions on brake discs facing toward the outside).



Tightening torque:

Brake disc to front wheel
(clean thread + Loctite 2701)..... 21 Nm

34 21 Removing and installing rear brake disc



Warning:

When removing and installing the brake caliper, force back the pistons carefully to ensure that the wheel-circuit reservoir does not overflow. If fluid escapes, proceed in accordance with “instructions for filling reservoir” (→ 34.28).

- Remove the brake caliper.
- Remove rear wheel.

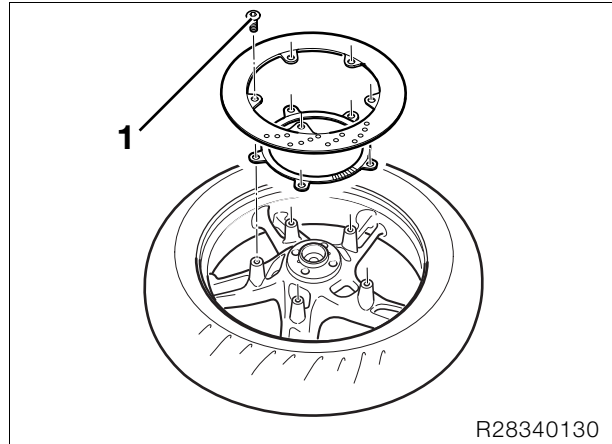

Note:

Retaining screws (1) are secured with thread-locking compound and should be heated if necessary before removal.

- Remove brake disc.
- Installation is the reverse of the removal procedure.
- Degrease the brake disc before installing.



Attention:

Make sure the spacer is fitted when the rear wheel is installed.



Tightening torque:

Brake disc to rear wheel drive
(clean thread + Loctite 2701)..... 21 Nm

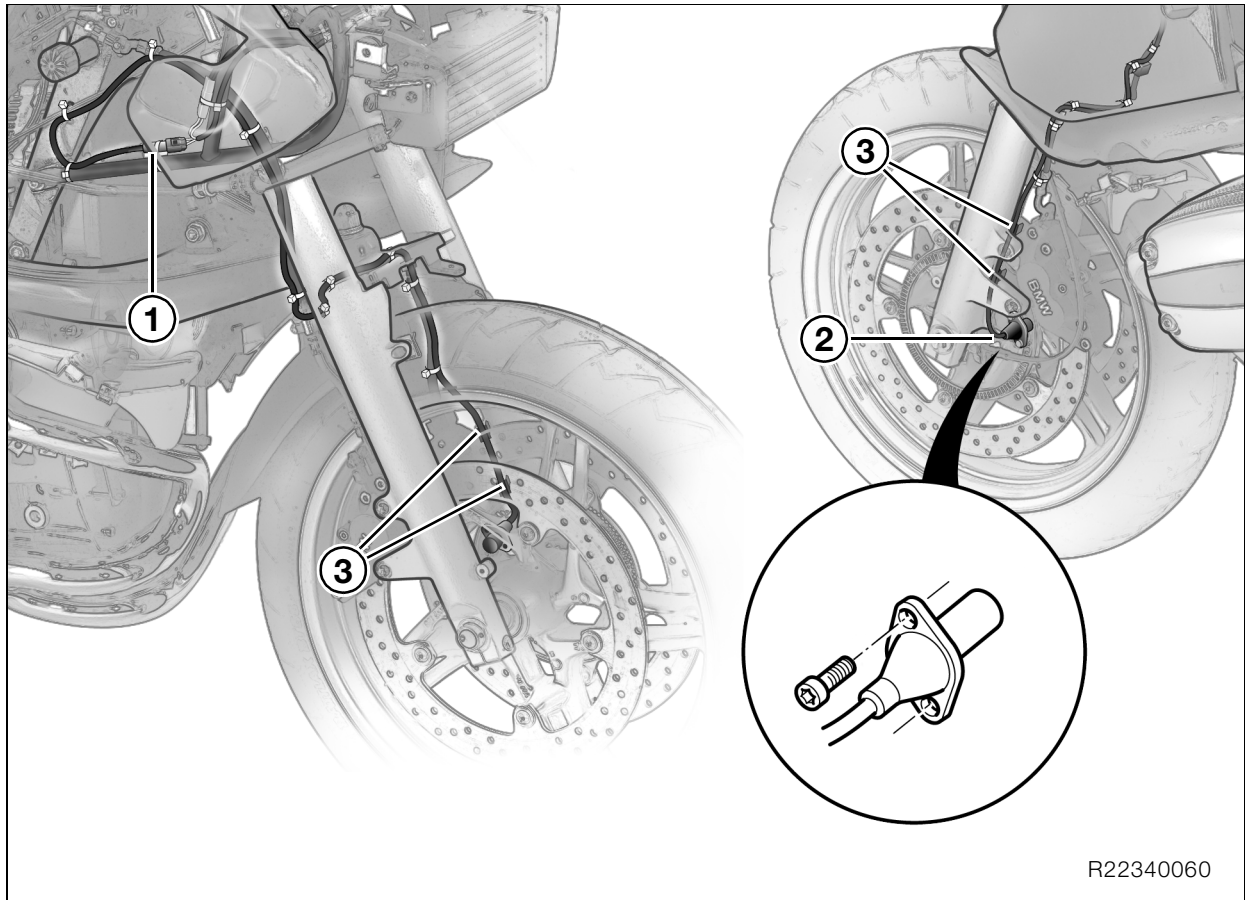

R22340060

Removing and installing Integral ABS sensor

34 52 044 Removing and installing front Integral ABS sensor

- Remove the cable ties securing the sensor cable.
- Disconnect plug (1) of sensor cable.
- Guide the sensor cable down until clear.
- Remove sensor (2).
- Installation is the reverse of the removal procedure.



Attention:

Route the sensor cable correctly.
Ensure that clips (3) are correctly seated.



Tightening torque:

Sensor hand-tight, 4 Nm

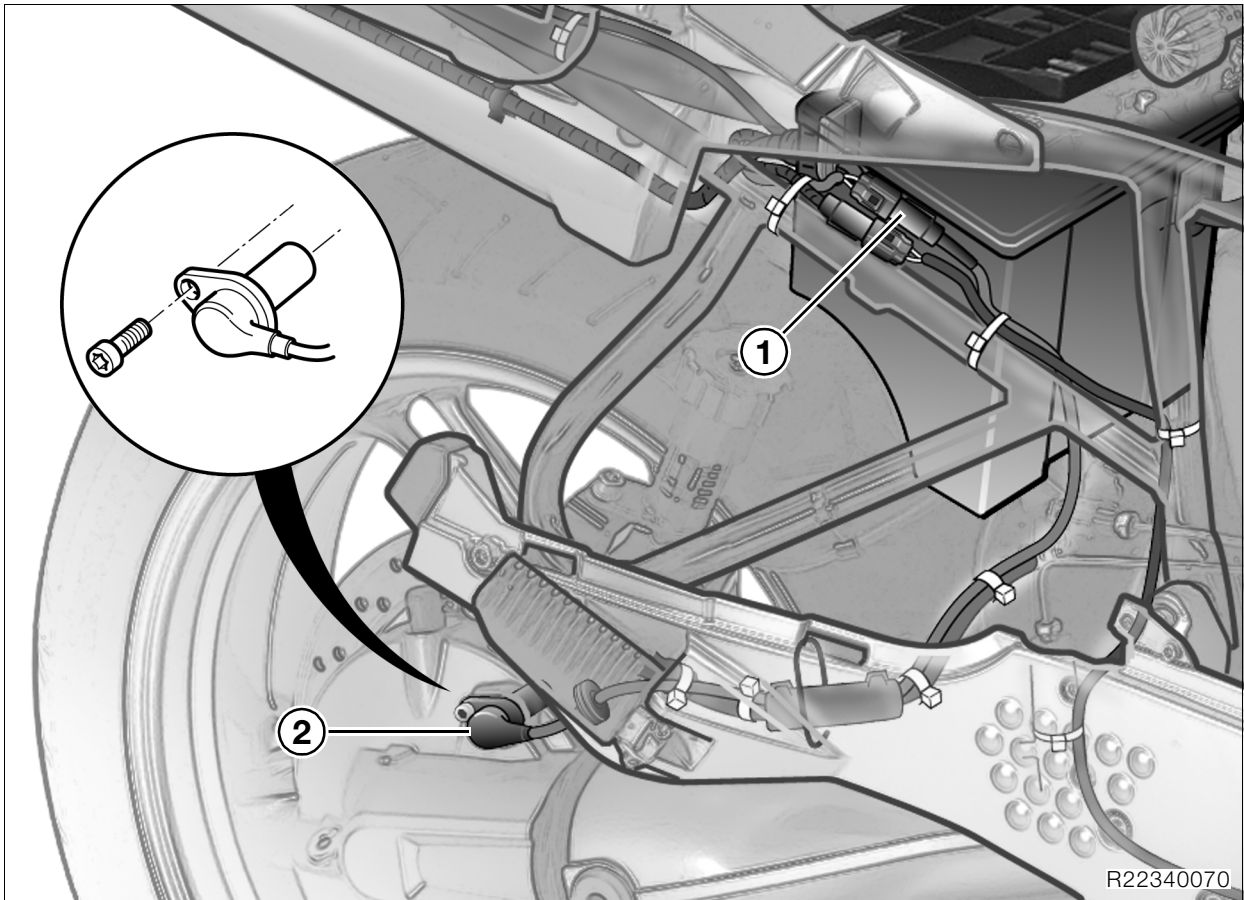
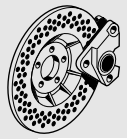

34 52 111 Removing and installing rear Integral ABS sensor

- Remove front and rear seats.
- Remove right case, if necessary.
- Remove small right side fairing panel.
- Remove the cable ties securing the sensor cable.
- Disconnect plug (1) of sensor cable.
- Before removing/installing, clean the sensor bore.
- Remove sensor (2).
- Installation is the reverse of the removal procedure.
- Coat O-rings with oil before installing.



Attention:

Route the sensor cable correctly.



Tightening torque:

Sensor hand-tight, 4 Nm

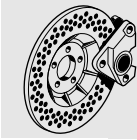
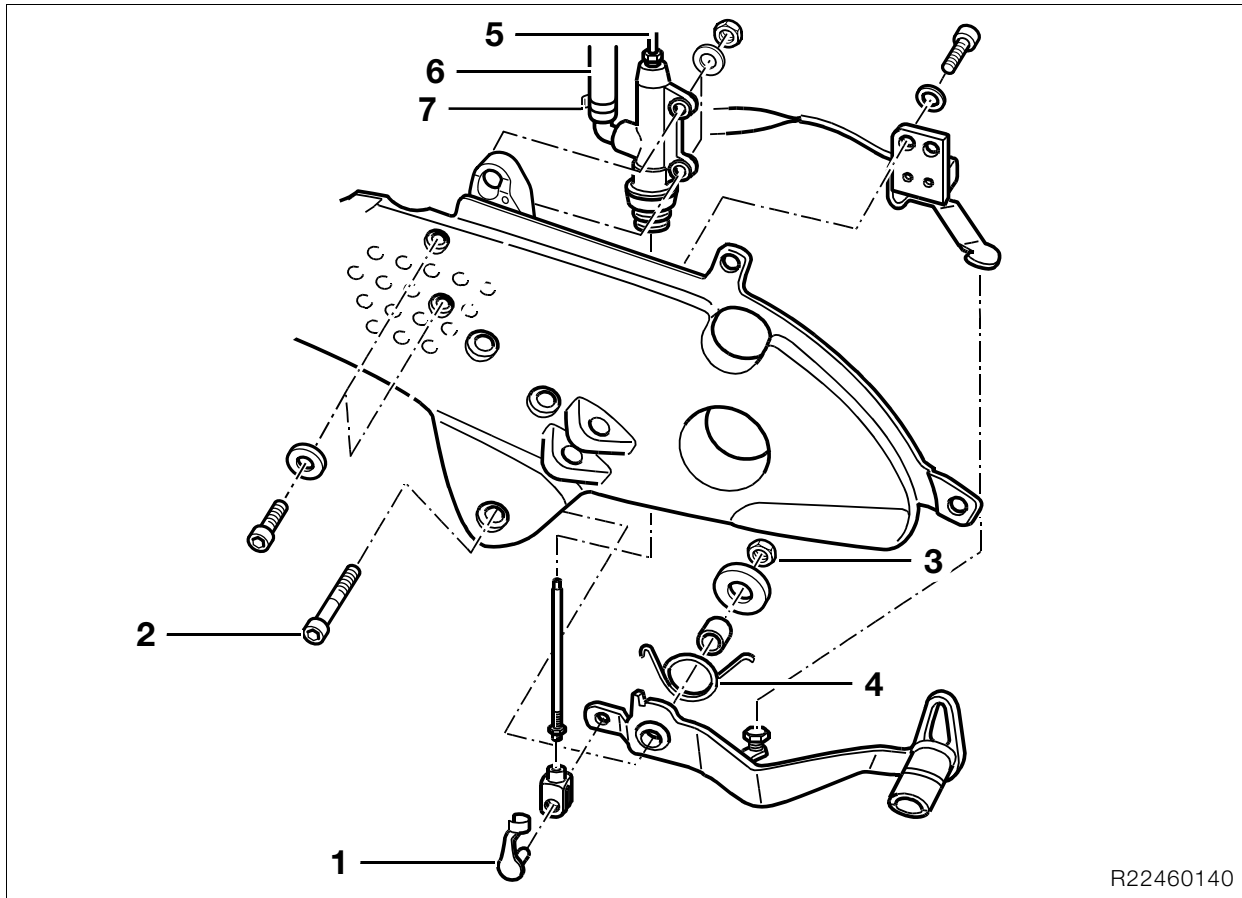

R22460140

35 21 Removing and installing footbrake lever

- Release and remove stud (1).
- Remove bolt (2) of footbrake lever with nut (3).
- Remove footbrake lever with torsion spring (4).
- Installation is the reverse of the removal procedure.
- Lubricate pivot bushing with **Shell Retinax A**.

Attention:

Check and, if necessary, adjust the blow-by clearance of the piston rod and the setting of the brake-light switch (→ 34.12).

Tightening torque:

Footbrake lever to footrest plate
(clean thread + apply Loctite 2701) 21 Nm

34 31 Removing and installing rear brake master cylinder

- Remove right side panel.

Attention:

Do not allow brake fluid to come into contact with painted parts of the motorcycle as brake fluid destroys paint.

- **Integral ABS** Drain rear control circuit (→ 34.18).
- Disconnect brake line (5) and hose (6).
- Release and remove stud (1).
- Remove brake master cylinder.
- Installation is the reverse of the removal procedure.
- Tighten non-reusable hose clip (7) with pliers, **BMW No. 13 1 500**.
- **Integral ABS** Fill and bleed rear control circuit (→ 34.21).

Attention:

Bleed the brake system carefully. Check and, if necessary, adjust the blow-by clearance of the piston rod and the setting of the brake-light switch (→ 34.12).

Tightening torque:

Master brake cylinder to footrest 9 Nm

Checking and adjusting blow-by clearance of piston rod

Checking blow-by clearance of piston rod

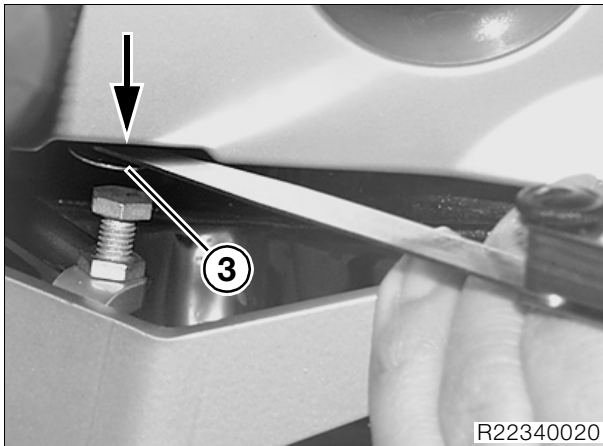

- Press the footbrake lever.
- Insert feeler gauge at right angles to direction of travel between the brake-light switch lever (3) and the stop on the footrest plate (arrow).
- Slowly release the footbrake lever and check play.

Play must be perceptible

Feeler gauge thickness:..... 0.15 mm (0.0059 in)

No play perceptible

Feeler gauge thickness:..... 0.35 mm (0.0137 in)

Adjusting blow-by clearance at piston rod

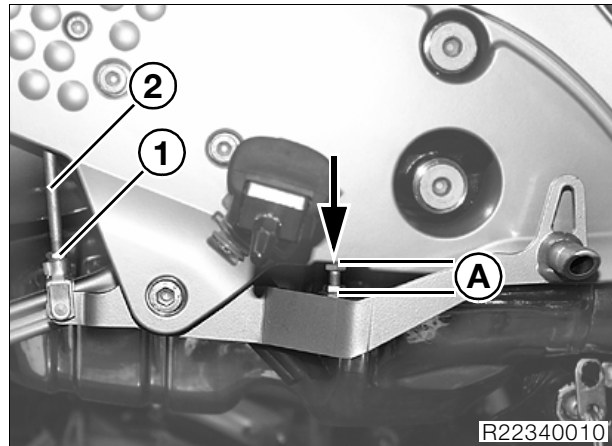

- Set the adjusting screw of the footbrake lever to distance A.

Distance A:.... 13.6 +/- 0.5 mm (0.5354+/-0.1969 in)
(Top edge of footbrake lever to top edge of adjusting screw.)

- Insert feeler gauge at right angles to direction of travel between the brake-light switch lever and the stop on the footrest plate (arrow).

Feeler gauge thickness:..... 0.2 mm (0.0078 in)

- Slacken locknut (1).
- Turn piston rod (2) clockwise toward the footbrake lever to obtain play.
- Carefully back off piston rod to take up play and tighten locknut.
- Remove the feeler gauge.
- Recheck play.
- Apply coloured sealing lacquer to the locknut.

Checking and adjusting setting of rear brake light switch

Checking setting of brake light switch, rear

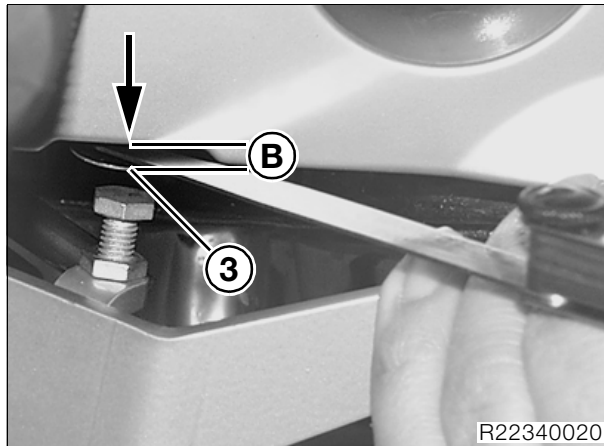

- Switch on the ignition.



Note:

After switching on the ignition, always wait for the BMW Integral ABS to complete its self-diagnosis. Do not operate the brake lever until self-diagnosis has completed.

- Depress the footbrake lever (brake light comes on and pump starts up).
- Insert feeler gauge at right angles to direction of travel between the brake-light switch lever (3) and the stop on the footrest plate (arrow).
- Slowly release the footbrake lever and check the point at which the switch trips.

Brake light switch must switch off

Feeler gauge thickness: 0.90 mm (0.0354 in)

Brake light switch must remain on

Feeler gauge thickness: 1.60 mm (0.0629 in)

- Switch off the ignition.

Adjusting brake light switch, rear

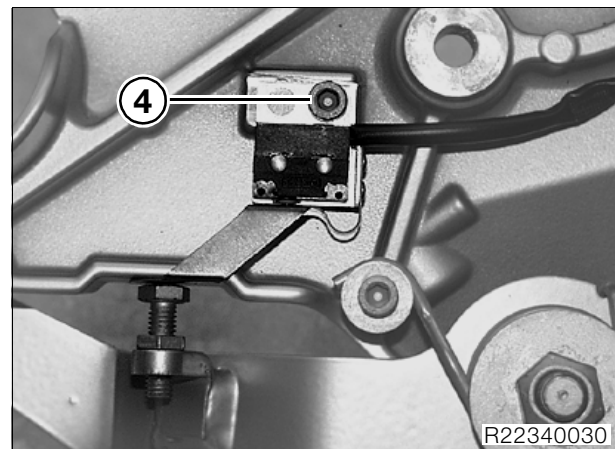

- Depress the footbrake lever and secure it in this position.
- Slacken screw (4).

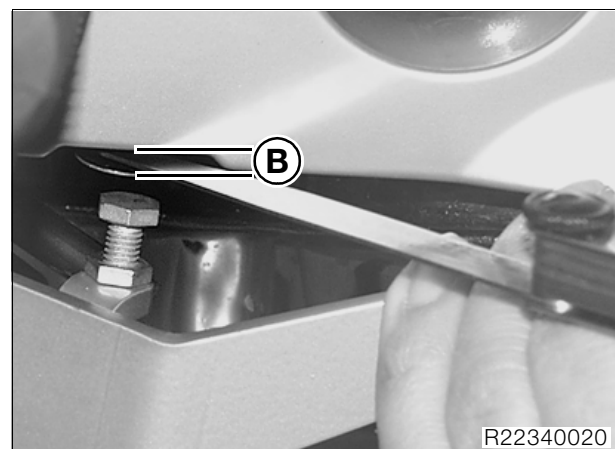

- Turn the brake light switch until the switch trips at distance (B).
- Hold the brake light switch and tighten the screw.
- Recheck the setting.

Distance B: 1 + 0.5 mm (0.0393 + 0.1968 in)
(clearance at switching point between brake-light switch lever and footrest plate).

Removing and installing piston in brake-lever fitting

➡ See Group 32



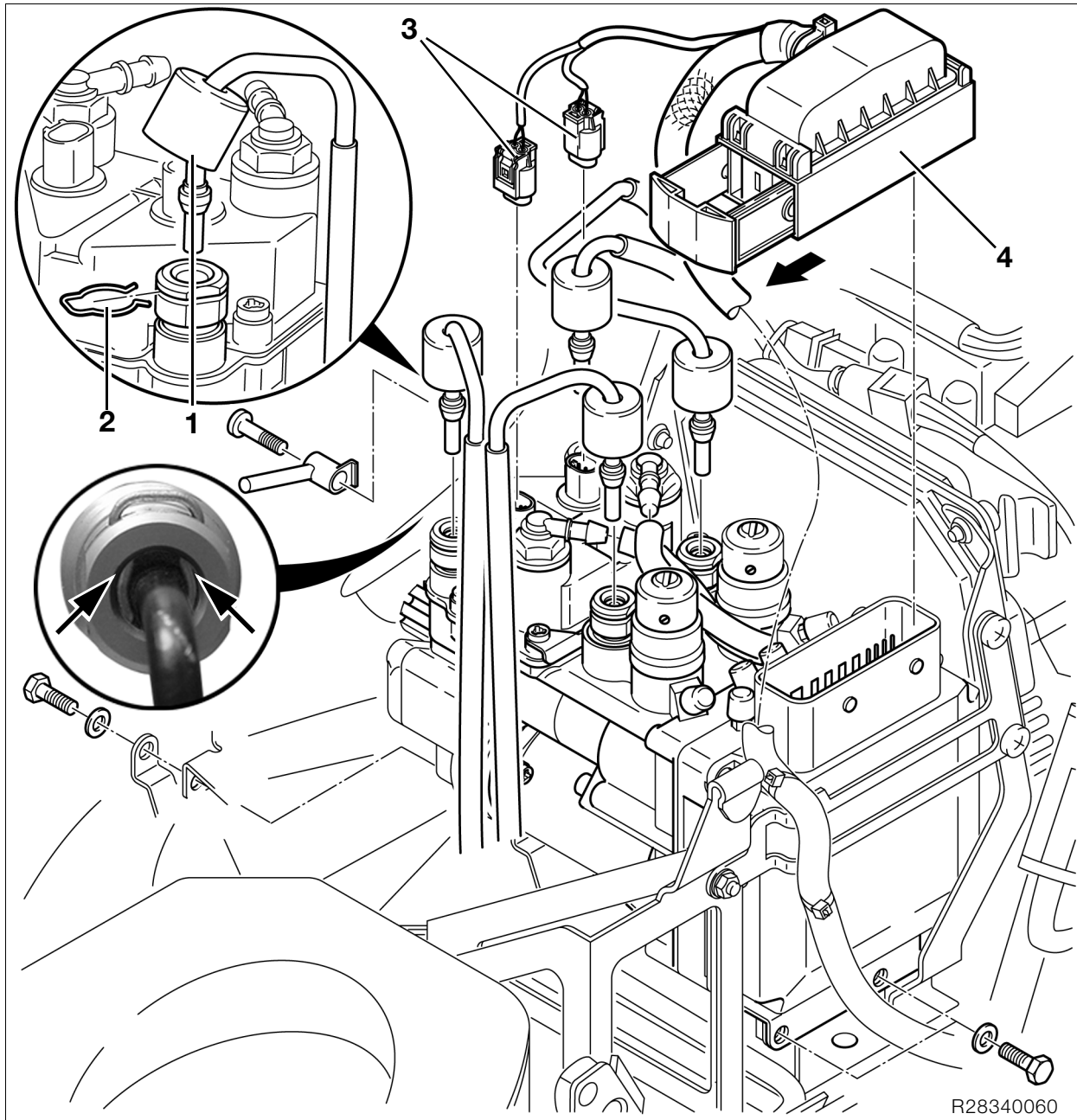

34 00 Removing and installing Integral ABS pressure modulator



Warning:

All repair and maintenance work on the BMW Integral ABS must be performed by trained, qualified specialists. Comply with all maintenance and repair instructions and always work through the various steps in the correct order. Use only new brake fluid from freshly opened containers.



Attention:

Do not allow brake fluid to come into contact with painted parts of the motorcycle as brake fluid destroys paint.

- Drain the brake system (→ 34.16).
- Disconnect ground lead from battery and insulate.
- Push protective caps (1) up.
- Remove spring clips (2).

**Attention:**

Do not bend the brake lines.

- Disconnect the brake lines from the ABS pressure modulator.

**Attention:**

Do not permit brake fluid to enter the plugs.

- Disconnect plugs (3) of the front and rear wheel circuit reservoirs.
- Unlock plug (4) (arrow) and disconnect the plug.
- Disconnect plug from Hall sensor.
- Remove Motronic control unit.
- Release ABS pressure modulator and pull it carefully to the left to remove.

Installing Integral ABS pressure modulator

- Installation is the reverse of the removal procedure: pay particular attention to the following.

**Note:**

Always replace the seals (square-section rings) between the brake lines and the pressure modulator **when you replace the brake lines.**

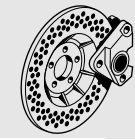
**Warning:**

Always fit new spring clips each time the plugs are disconnected. Ensure correct positioning.

- Install new spring clips.
- Slip the protective caps up the brake lines.
- Clip in brake lines.
- Check that spring clips are correctly positioned (arrows).
- Seat the protective caps on the connectors.
- Connect the battery.
- Fill and bleed the brake system (→ 34.19).
- After all the work on the brake system has been completed, run a bleed test using the **BMW MoDiTeC** (→ 34.29).

**Note:**

Disconnecting the battery means that the entries in the fault memory of the Motronic MA2.4 control unit are deleted and the adaptation values are reset. This can temporarily impair the operating characteristics when the engine is restarted.

- Switch on the ignition.
- Without starting the engine, fully open the throttle once or twice so that the Motronic control unit can register the throttle-valve positions.

**Tightening torque:**

ABS pressure modulator to battery carrier ... 10 Nm
 ABS pressure modulator to holder 7 Nm

34 00 Draining the Integral ABS brake system



Warning:

All repair and maintenance work on the BMW Integral ABS must be performed by trained, qualified specialists. Comply with all maintenance and repair instructions and always work through the various steps in the correct order. Use only new brake fluid from freshly opened containers.



Note:

This description applies for the brake filling and bleeding unit with extraction of the brake fluid by partial vacuum. If other devices are used, comply with their manufacturers' instructions.

- Remove front and rear seats.
- Remove fuel tank.

Drain both wheel circuits



Attention:

Do not allow brake fluid to come into contact with painted parts of the motorcycle as brake fluid destroys paint.

Draining front wheel circuit



Attention:

Integral brakes, the rear brake must be ready for use.



- Open front wheel-circuit reservoir (1).



Attention:

To prevent brake fluid entering plugs, do not disconnect plugs from the ABS pressure modulator.

- Draw off the old brake fluid from the wheel-circuit reservoir and reinstall the cap.
- Remove front brake pads.

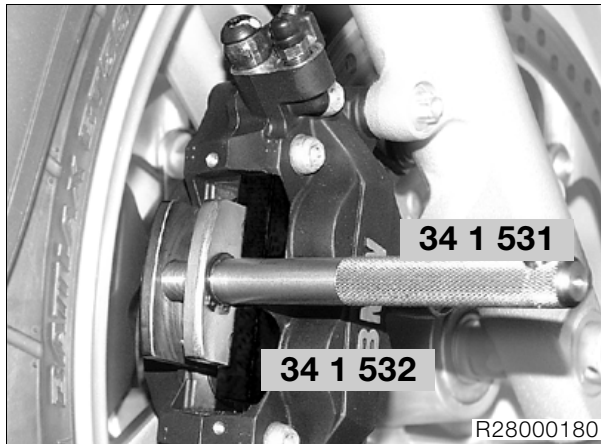

Attention:

Do not scrape the wheel – mask it off if necessary.

- Use resetting tool, **BMW No. 34 1 531**, and locator, **BMW No. 34 1 532**, to force the pistons in the left and right brake calipers all the way back and hold them in this position.
- Wrap cloths around the left and right brake calipers.
- Connect the brake bleeding device to the bleed screw of the left brake caliper, but **do not switch on** the device.
- Switch on the ignition.



Note:

After switching on the ignition, always wait for the BMW Integral ABS to complete its self-diagnosis. Do not operate the brake lever until self-diagnosis has completed.

- Gently pull the handbrake lever until the pump just starts up.
- Open the bleed screw.
- Drain the wheel circuit with the pump.
- Close the bleed screw.
- Release the brake.
- Disconnect the brake bleeding device from the bleed screw.
- The procedure for draining the right brake caliper is the same as that for the left caliper.
- Close the bleed screw.
- Release the brake and switch off the ignition.
- Disconnect the brake bleeding device from the bleed screw.

Draining rear wheel circuit



Attention:

Integral brakes, the rear brake must be ready for use.

- Install front brake pads, if applicable.

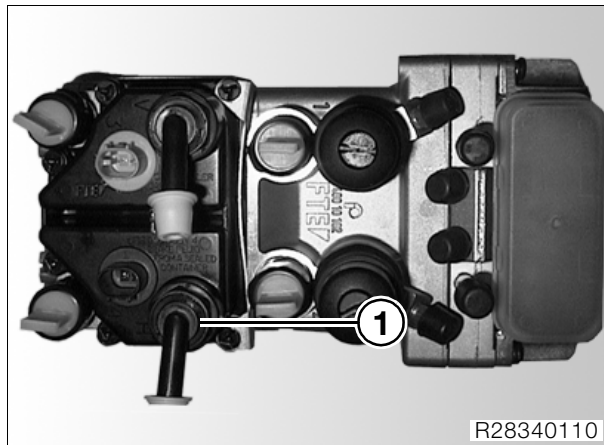

- Open rear wheel-circuit reservoir (1).



Attention:

To prevent brake fluid entering the plugs, do not disconnect the plugs from the ABS pressure modulator.

- Draw off the old brake fluid from the wheel-circuit reservoir and reinstall the cap.
- Remove rear brake pads.

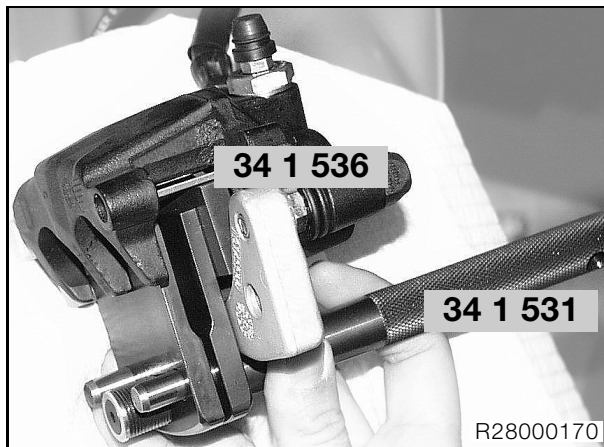

- Install adapter, **BMW No. 34 1 536**, instead of the outboard brake pad.
- Install resetting tool, **BMW No. 34 1 531**, with the handle toward the outside in the rear brake caliper, press the pistons fully back and secure them in this position.
- Wrap a cloth around the brake caliper.
- Connect the brake bleeding device to the bleed screw, but do not switch on the device.
- Switch on the ignition.



Note:

After switching on the ignition, always wait for the BMW Integral ABS to complete its self-diagnosis. Do not operate the brake lever until self-diagnosis has completed.

- Gently press the footbrake lever until the pump just starts up.
- Open the bleed screw.
- Drain the wheel circuit with the pump.
- Close the bleed screw.
- Release the brake and switch off the ignition.
- Disconnect the brake bleeding device from the bleed screw.

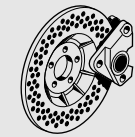

Draining control circuits



Attention:

Do not allow brake fluid to come into contact with painted parts of the motorcycle as brake fluid destroys paint.



Draining front control circuit

- Turn the front wheel to a position in which the brake fluid reservoir is horizontal and secure the handlebars in this position.
- Wrap cloths around the reservoir.
- Remove front reservoir cap with rubber diaphragm.
- Draw off old brake fluid and clean the reservoir.

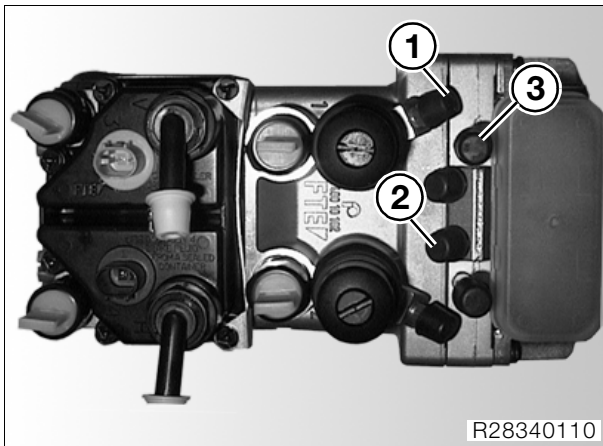

- Draw off the brake fluid from the circuits in the correct sequence, using ring spanner, **BMW No. 34 2 532**:
 - front metering cylinder (1),
 - front integral circuit (2) and
 - front control circuit (3).

Draining rear control circuit

- Remove rear reservoir cap with rubber diaphragm, draw off the old brake fluid and clean the reservoir.

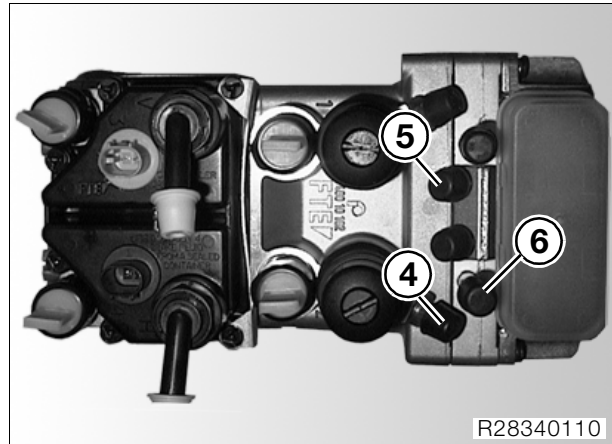

- Draw off the brake fluid from the circuits in the correct sequence, using ring spanner, **BMW No. 34 2 532**:
 - rear metering cylinder (4),
 - rear integral circuit (5) and
 - rear control circuit (6).

34 00 Filling and bleeding Integral ABS system



Warning:

All repair and maintenance work on the BMW Integral ABS must be performed by trained, qualified specialists.

Comply with all maintenance and repair instructions and always work through the various steps in the correct order.

Use only new brake fluid from freshly opened containers.



Note:

This description applies for the brake filling and bleeding unit with extraction of the brake fluid by partial vacuum.

If other devices are used, comply with their manufacturers' instructions.

- Place motorcycle on its centre stand.
- Remove front and rear seats.
- Remove fuel tank.

Filling and bleeding control circuits



Attention:

Do not allow brake fluid to come into contact with painted parts of the motorcycle as brake fluid destroys paint.

Filling the front control circuit

- Turn the front wheel to a position in which the brake fluid reservoir is horizontal and secure the handlebars in this position.
- Wrap cloths around the reservoir.
- Remove front reservoir cap with rubber diaphragm.

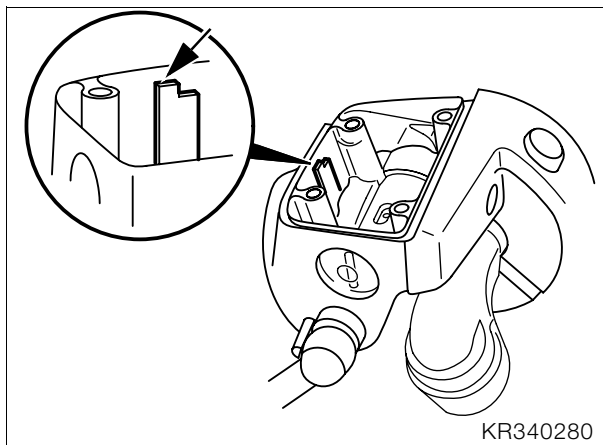

- Top up the brake fluid level to the "MAX" mark (arrow).



Attention:

During the filling and bleeding procedure, make sure that the fluid replenishing hole is always below the level of the brake fluid, or else air will be drawn into the brake system.

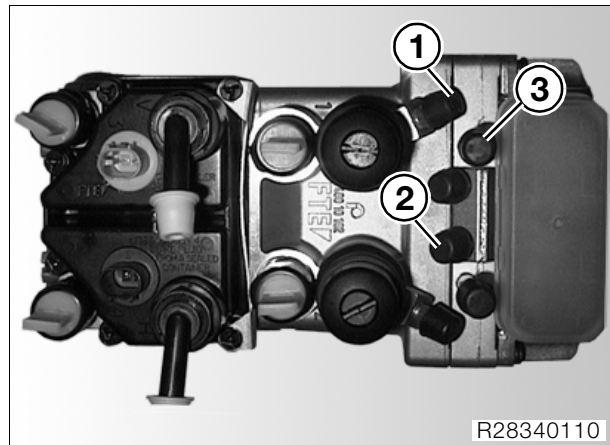

- Draw off the brake fluid from the circuits in the correct sequence while topping up continuously with fresh brake fluid and using ring spanner, **BMW No. 34 2 532**:
 - front metering cylinder (1),
 - front integral circuit (2),
 - front control circuit (3) and
 - front metering cylinder (1) for the second time.



Attention:

On account of the vacuum extraction process, it is not possible to tell whether there is brake fluid in the hose of the brake bleeding device when it is free of bubbles.

Consequently, **the system must be bled again manually in the specified sequence and in accordance with the instructions for bleeding the brakes.**

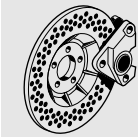

Bleeding front control circuit

- Seal the reservoir by installing the rubber diaphragm and the reservoir cap.
- Turn the handlebars to full left lock.
- Repeatedly pull front brake lever lightly to expel air from brake master cylinder.
- Switch off the brake bleeding device.
- Set the handbrake lever to position 4.

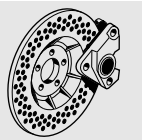

 **Warning:**

When performing maintenance and repair work on BMW Integral ABS, never pump quickly or vigorously.

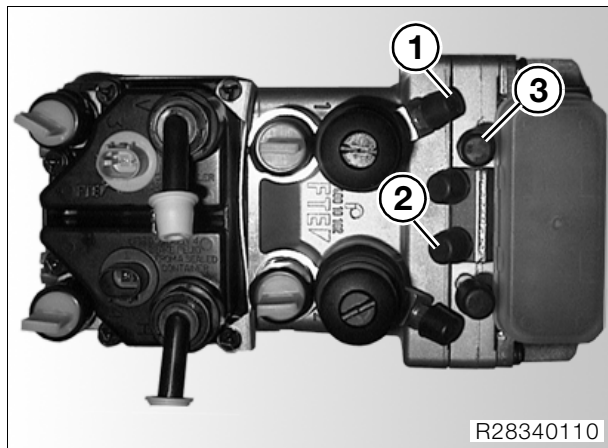

- Remove reservoir cap with rubber diaphragm.
- In the following sequence, bleed:
 - front metering cylinder (1),
 - front integral circuit (2),
 - front control circuit (3) and
 - front metering cylinder (1) for the second time using ring spanner, **BMW No. 34 2 532**, in accordance with instructions for bleeding.

Instructions for bleeding:

1. Slowly pull brake lever until brake-light switch clicks (blow-by bore closed).
2. Open the bleed screw.
3. Slowly pull brake lever to full extent of its travel and close the bleed screw.
4. Slowly release the brake lever.
5. Repeat steps 1 to 4 until the brake fluid is clear and free of bubbles.

- Fit the protective caps on the bleed screws.
- Add brake fluid up to the “MAX” mark.
- Wipe the rim of the reservoir, the rubber diaphragm and the cover to remove brake fluid, and carefully re-assemble the components.

- Recheck the brake-fluid level.
- Place the motorcycle on its centre stand.
- Turn the handlebars fully to the **left**.

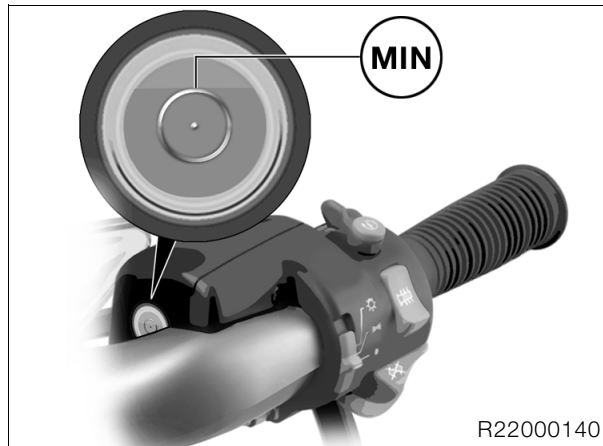

Specified level

not below MIN
(top edge of the marking ring)

 **Attention:**

After all the work on the brake system has been completed, run a bleed test using the **BMW MoDiTeC**.

Brake fluidDOT 4

Filling the rear control circuit

- Remove rear reservoir cap with rubber diaphragm.

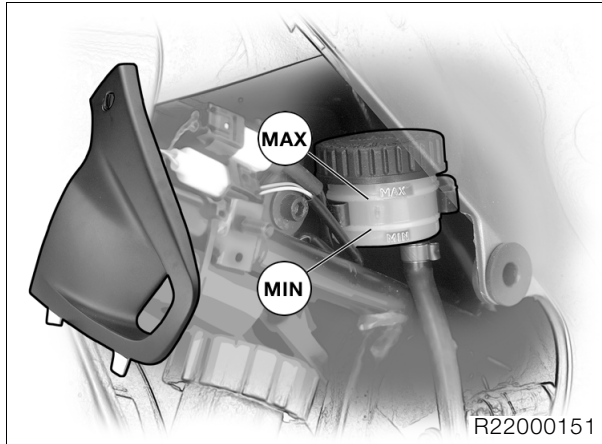

- Top up the brake fluid level to the "MAX" mark.

Attention:

While filling and bleeding the system, do not allow the brake fluid level to drop below the "MIN" mark, as otherwise air will be drawn into the brake system.

Warning:

When performing maintenance and repair work on BMW Integral ABS, never pump quickly or vigorously.

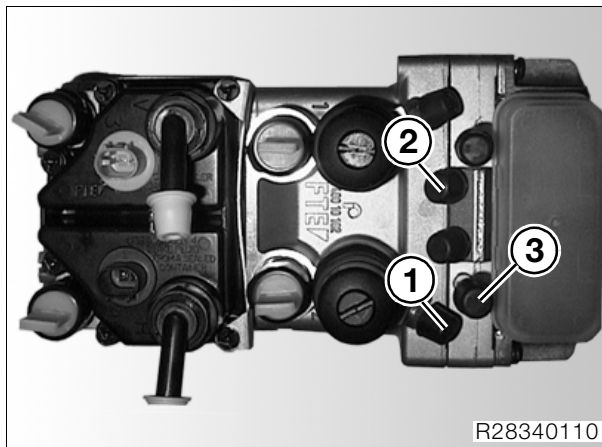

- Draw off the brake fluid from the circuits in the correct sequence while topping up continuously with fresh brake fluid and using ring spanner, **BMW No. 34 2 532**:
 - rear metering cylinder (1),
 - rear integral circuit (2),
 - rear control circuit (3) and
 - rear metering cylinder (1) for the second time.

Attention:

On account of the vacuum extraction process, it is not possible to tell whether there is brake fluid in the hose of the brake bleeding device when it is free of bubbles.

Consequently, **the system must be bled again manually in the specified sequence and in accordance with the instructions for bleeding the brakes.**

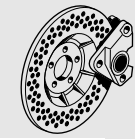

Bleeding the rear control circuit

- Switch off the brake bleeding device.
- In the following sequence, bleed:
 - rear metering cylinder (1),
 - rear integral circuit (2),
 - rear control circuit (3) and
 - rear metering cylinder (1) for the second time using ring spanner, **BMW No. 34 2 532**, in accordance with instructions for bleeding.

Instructions for bleeding:

1. Slowly depress brake lever until brake-light switch clicks (blow-by bore closed).
2. Open the bleed screw.
3. Slowly depress brake lever to full extent of its travel and close the bleed screw.
4. Slowly release the brake lever.
5. Repeat steps 1 to 4 until the brake fluid is clear and free of bubbles.

- Fit the protective caps on the bleed screws.
- Top up the brake fluid at least until the level reaches the “MIN” mark.
- Wipe the rim of the reservoir, the rubber diaphragm and the cover to remove brake fluid, and carefully re-assemble the components.
- Recheck the brake-fluid level.
- Place the motorcycle on its centre stand.

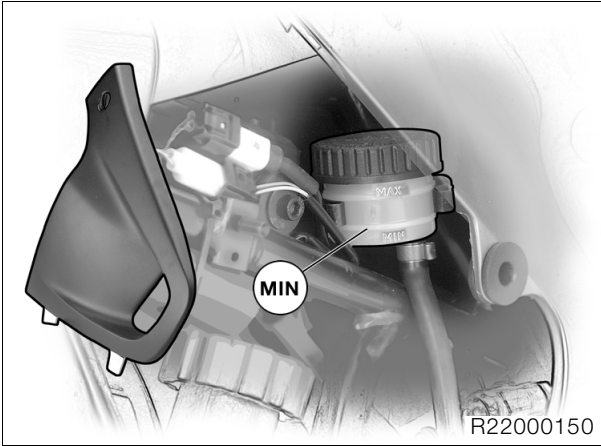
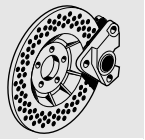

Specified level

not below MIN



Attention:

After all the work on the brake system has been completed, run a bleed test using the **BMW MoDiTeC**.

Brake fluid.....DOT 4

Filling and bleeding wheel circuits

Attention:

Do not allow brake fluid to come into contact with painted parts of the motorcycle as brake fluid destroys paint.

Filling and bleeding front wheel circuit

Attention:

Integral brakes, the rear brake must be ready for use.

- Install rear brake pads and brake caliper, if applicable.
- Place the motorcycle on its centre stand.

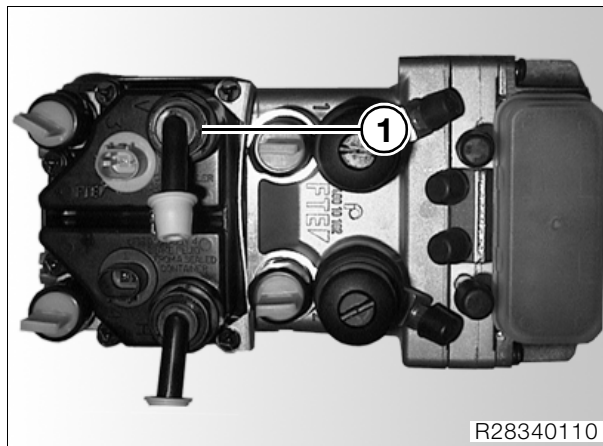

- Open front wheel-circuit reservoir (1).
- Remove front brake pads.
- Wrap cloths around the left and right brake calipers.

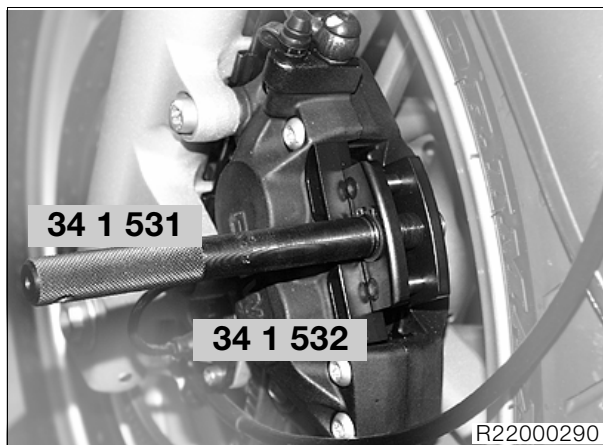

Attention:

Do not scrape the wheel – mask it off if necessary.

- Use resetting tool, **BMW No. 34 1 531**, and locator, **BMW No. 34 1 532**, to force the pistons in the left and right brake calipers all the way back and hold them in this position.

Attention:

To prevent brake fluid entering the plugs, do not disconnect the plugs from the ABS pressure modulator.

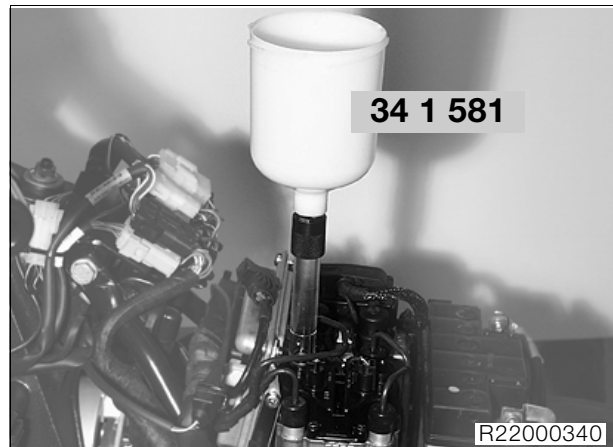

- Screw container, **BMW No. 34 1 581**, onto front wheel circuit reservoir.
- Slowly fill container, **BMW No. 34 1 581**, with new brake fluid until it is approximately 1/2 full.
- Connect the brake bleeding device to the bleed screw of the left brake caliper, but **do not switch on** the device.

Note:

If necessary, use a cable tie to secure the bleed hose to the bleed screw.

- Switch on the ignition.

Note:

After switching on the ignition, always wait for the BMW Integral ABS to complete its self-diagnosis. Do not operate the brake lever until self-diagnosis has completed.

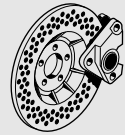

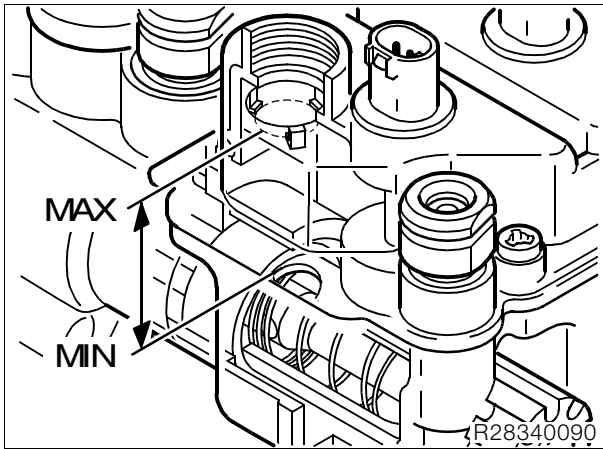

⚠ Attention:

The brake fluid must always be visible in the container, because the piston in the base of the wheel-circuit reservoir must always be covered by the fluid. The procedure must be repeated if the fluid drops below the “min” level.

- Gently pull the handbrake lever until the pump just starts up.
- Open the bleed screw, while topping up the container with new brake fluid if necessary.
- Pump out the brake fluid with virtually no pressure to begin with, then vary the brake pressure.

📄 Note:

The higher the brake pressure the faster the fluid is pumped through the system, which means that the level in the wheel-circuit reservoir drops all the more rapidly.

- Pump off brake fluid until it emerges clear and free from air bubbles.
- Close the bleed screw.
- Release the brake.
- Disconnect the brake bleeding device from the bleed screw.
- Connect the brake bleeding device to the bleed screw of the right brake caliper, but **do not switch on** the device.



Note:

If necessary, use a cable tie to secure the bleed hose to the bleed screw.

- The procedure for changing the brake fluid in the right brake caliper is the same as that for the left caliper.
- When the brake fluid is clear and free of bubbles, continue pumping until the fluid in the container just disappears from view.
- Close the bleed screw.
- Release the brake and switch off the ignition.
- Disconnect the brake bleeding device from the bleed screw.
- Disconnect the container from the wheel-circuit reservoir.



⚠ Attention:

After changing and/or bleeding the brakes, always top up the fluid in the wheel-circuit reservoir to the correct level in accordance with the instructions.

Instructions for filling front wheel circuit reservoir



Attention:

Integral brakes, the rear brake must be ready for use.

- Install front brake pads, if applicable.

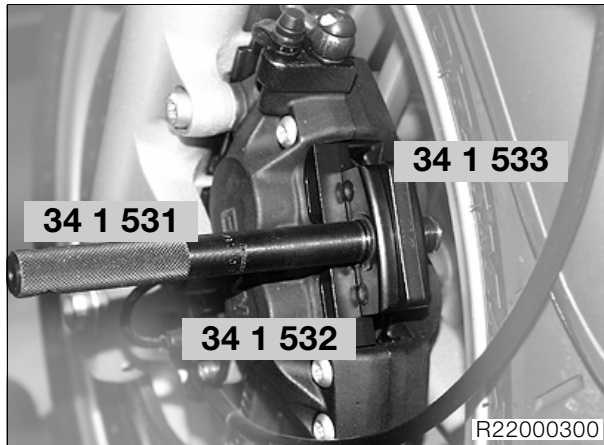

- Top up fluid in front wheel-circuit reservoir to “MAX” if necessary
- Install adapters 22, **BMW No. 34 1 533**, in resetting tool, **BMW No. 34 1 531/532**, for both front brake calipers, and tighten the resetting tool until the adapters are secure.



Attention:

The piston in the base of the wheel-circuit reservoir must always be covered by the fluid, as otherwise air can be drawn into the brake system. Bleed the system again if this happens.

- Switch on the ignition.



Note:

After switching on the ignition, always wait for the BMW Integral ABS to complete its self-diagnosis. Do not operate the brake lever until self-diagnosis has completed.

- Pull handbrake lever until the pistons of the front brake calipers are in contact with resetting tool, **BMW No. 34 1 531**.

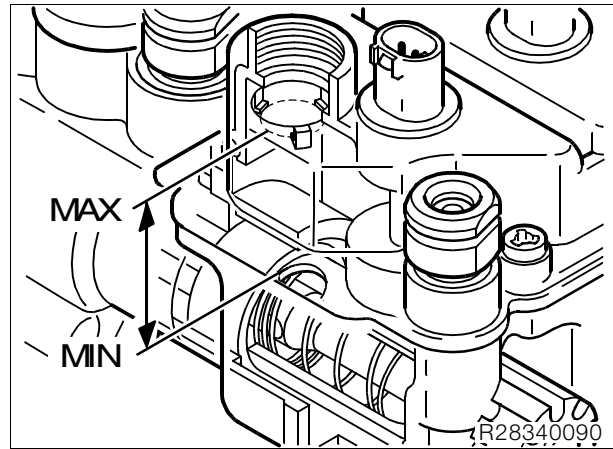

- Top up the fluid in the wheel-circuit reservoir until one of the three protrusions in the filler neck just touches the surface of the fluid (arrow).
- Screw container, **BMW No. 34 1 581**, onto front wheel circuit reservoir.
- Remove adapter, **BMW No. 34 1 533**, and force back pistons far enough to allow the brake pads to be fitted.
- Install front brake pads.
- With the ignition switched on, bed in the brake pads against the brake discs.
- Disconnect the container from the wheel-circuit reservoir.
- Hand-tighten cap of front wheel-circuit reservoir.
- Check operation of the brake system with the ignition switched on.



Attention:

After all the work on the brake system has been completed, run a bleed test using the **BMW MoDiTeC** and check the fault code memory!

Brake fluidDOT 4



Tightening torque:

Bleed screw in front brake caliper 7 Nm

Filling and bleeding rear wheel circuit

Attention:

Integral brakes, the front brake must be ready for use.

- Place the motorcycle on its centre stand.

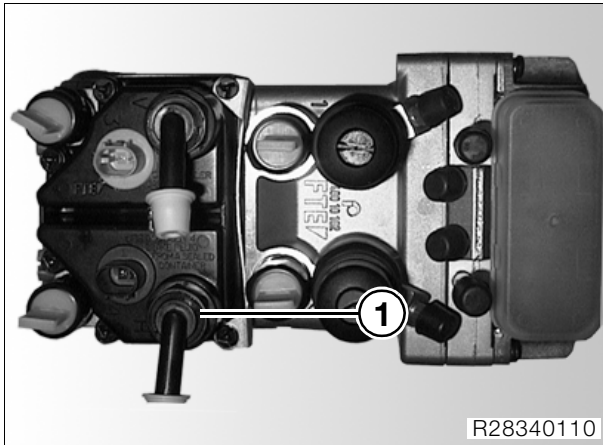

- Open rear wheel-circuit reservoir (1).
- Remove rear brake pads.

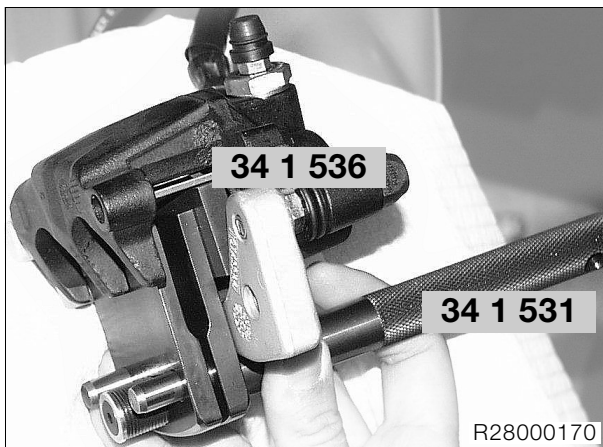

- Install adapter, **BMW No. 34 1 536**, instead of the outboard brake pad.
- Install resetting tool, **BMW No. 34 1 531**, with the handle toward the outside in the rear brake caliper, press the pistons fully back and secure them in this position.

Attention:

To prevent brake fluid entering the plugs, do not disconnect the plugs from the ABS pressure modulator.

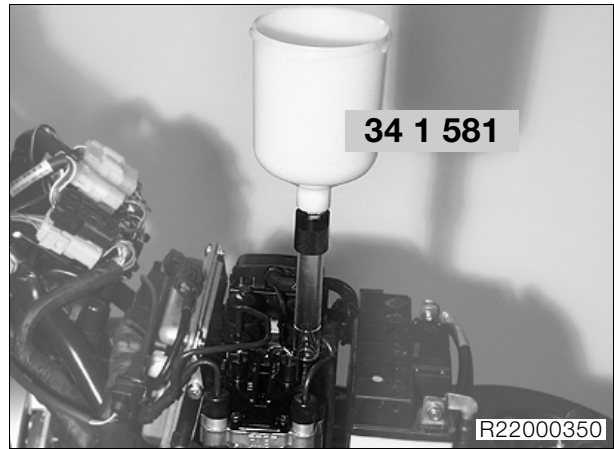

- Screw container, **BMW No. 34 1 581**, onto rear wheel circuit reservoir.
- Slowly fill container, **BMW No. 34 1 581**, with new brake fluid until it is approximately 1/3 full.
- Connect the brake bleeding device to the bleed screw, but **do not switch on** the device.



Note:

If necessary, use a cable tie to secure the bleed hose to the bleed screw.

- Switch on the ignition



Note:

After switching on the ignition, always wait for the BMW Integral ABS to complete its self-diagnosis. Do not operate the brake lever until self-diagnosis has completed.

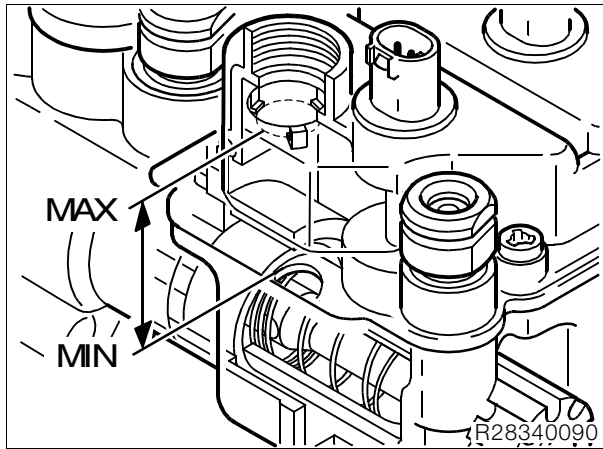

- Close the bleed screw.
- Release the brake and switch off the ignition.
- Disconnect the brake bleeding device from the bleed screw.
- Disconnect the container from the wheel-circuit reservoir.

⚠ Attention:

After changing and/or bleeding the brakes, always top up the fluid in the wheel-circuit reservoir to the correct level in accordance with the instructions.



⚠ Attention:

The brake fluid must always be visible in the container, because the piston in the base of the wheel-circuit reservoir must always be covered by the fluid. The procedure must be repeated if the fluid drops below the "min" level.

- Very gently press the footbrake lever until the pump just starts up.
- Open the bleed screw, while topping up the container with new brake fluid if necessary.
- Pump out the brake fluid with virtually no pressure to begin with, then vary the brake pressure.

📖 Note:

The higher the brake pressure the faster the fluid is pumped through the system, which means that the level in the wheel-circuit reservoir drops all the more rapidly.

- When the brake fluid is clear and free of bubbles, continue pumping until the fluid in the container just disappears from view.

Instructions for filling rear wheel circuit reservoir



Attention:

Integral brakes, the front brake must be ready for use.

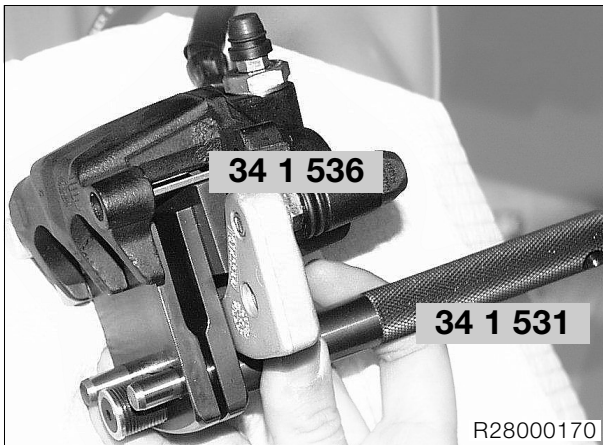
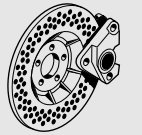

- Top up fluid in rear wheel-circuit reservoir to "MAX" if necessary.
- Fully tighten resetting tool, **BMW No. 34 1 531**, and adapter, **BMW No. 34 1 536**.



Attention:

The piston in the base of the wheel-circuit reservoir must always be covered by the fluid, as otherwise air can be drawn into the brake system. Bleed the system again if this happens.

- Switch on the ignition.



Note:

After switching on the ignition, always wait for the BMW Integral ABS to complete its self-diagnosis. Do not operate the brake lever until self-diagnosis has completed.

- Operate the footbrake lever until the pistons of the rear brake caliper are in contact with resetting tool, **BMW No. 34 1 531**, and adapter, **BMW No. 34 1 536**.

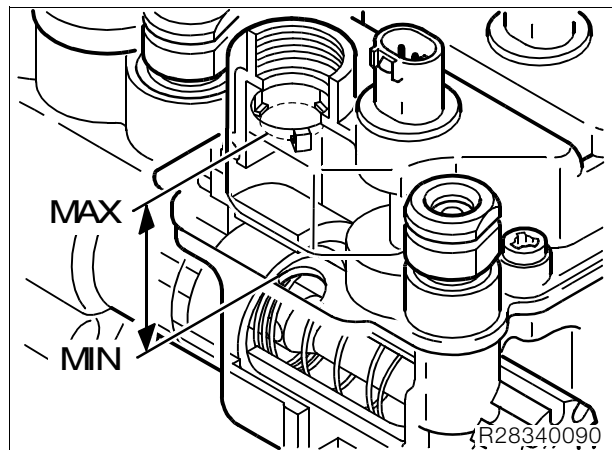

- Top up the fluid in the wheel-circuit reservoir until one of the three protrusions in the filler neck just touches the surface of the fluid (arrow).
- Remove resetting tool, **BMW No. 34 1 531**, and adapter, **BMW No. 34 1 536**.



Warning:

Make sure that the wheel-circuit reservoir does not overflow when the brake pads/brake calipers are installed.

- Install rear brake pads and brake caliper.
- Disconnect the container from the wheel-circuit reservoir.
- Hand-tighten cap of rear wheel-circuit reservoir.
- Check operation of the brake system with the ignition switched on.



Attention:

After all the work on the brake system has been completed, run a bleed test using the **BMW MoDiTeC**.

- Perform bleed test with **BMW MoDiTeC**.
- Install fuel tank.

Brake fluid.....DOT 4



Tightening torque:

Bleed screw in rear brake caliper 5 Nm
 Brake caliper to rear wheel drive 40 Nm

34 00 Integral ABS
Reading fault memory with
BMW MoDiTeC

- Remove front and rear seats.
- Connect the **BMW MoDiTeC** to the diagnosis connector.
- Read out the fault memory.
- Clear the fault memory if applicable, or perform all requisite repair work.

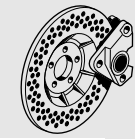

34 00 Integral ABS
Performing bleed test with
BMW MoDiTeC

- Remove front and rear seats.
- Connect the **BMW MoDiTeC** to the diagnosis connector.



Warning:

When performing maintenance and repair work on BMW Integral ABS, never pump quickly or vigorously.

- Perform bleed test.
- Perform all requisite repair work.

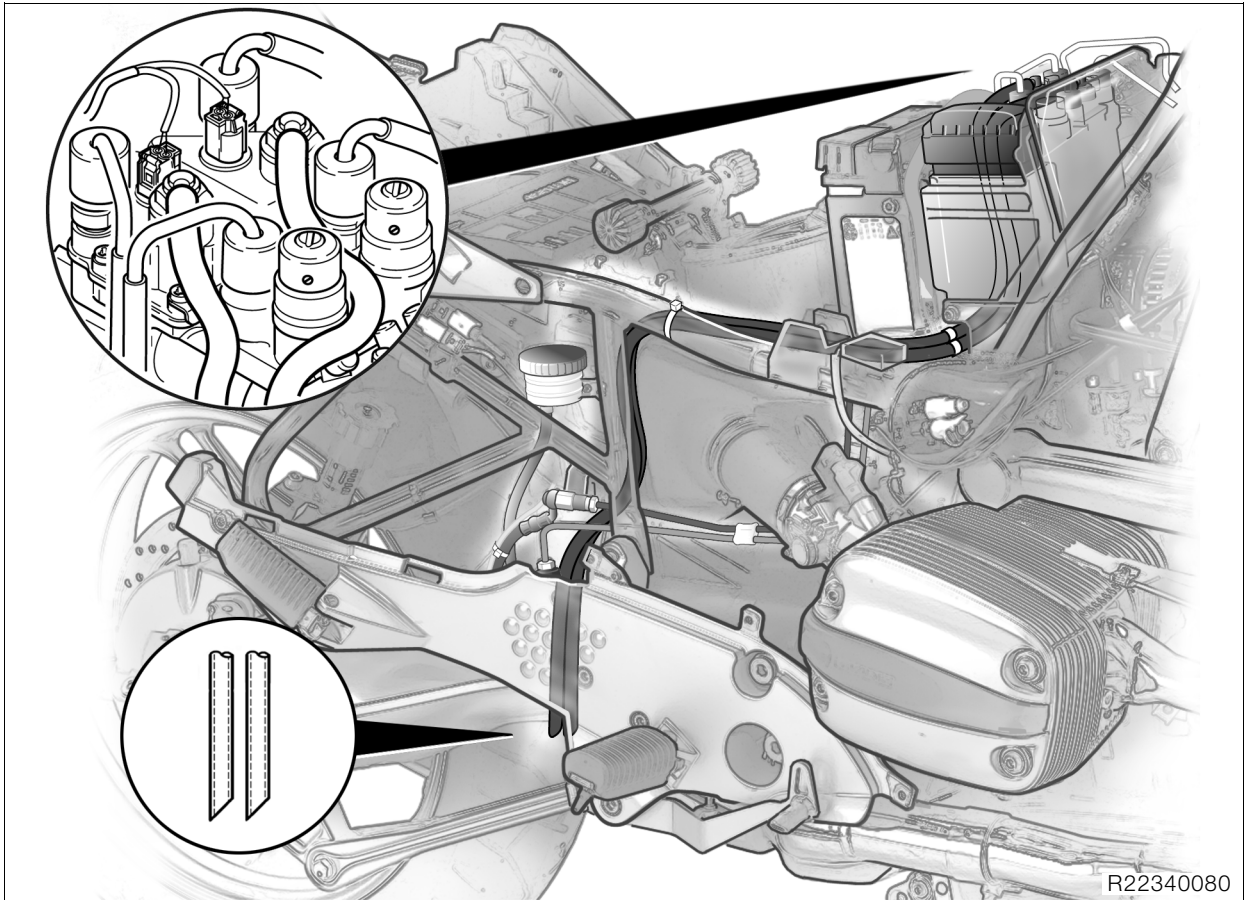

34 51 Integral ABS Removing and installing bleed lines, wheel circuit reservoirs

- Remove caps of wheel circuit reservoirs complete with bleed lines.
- Installation is the reverse of the removal procedure. Pay particular attention to the following:
- Make sure the bleed lines are free of kinks.
- Cut the bleed lines to length if necessary, and cut the ends at an angle.

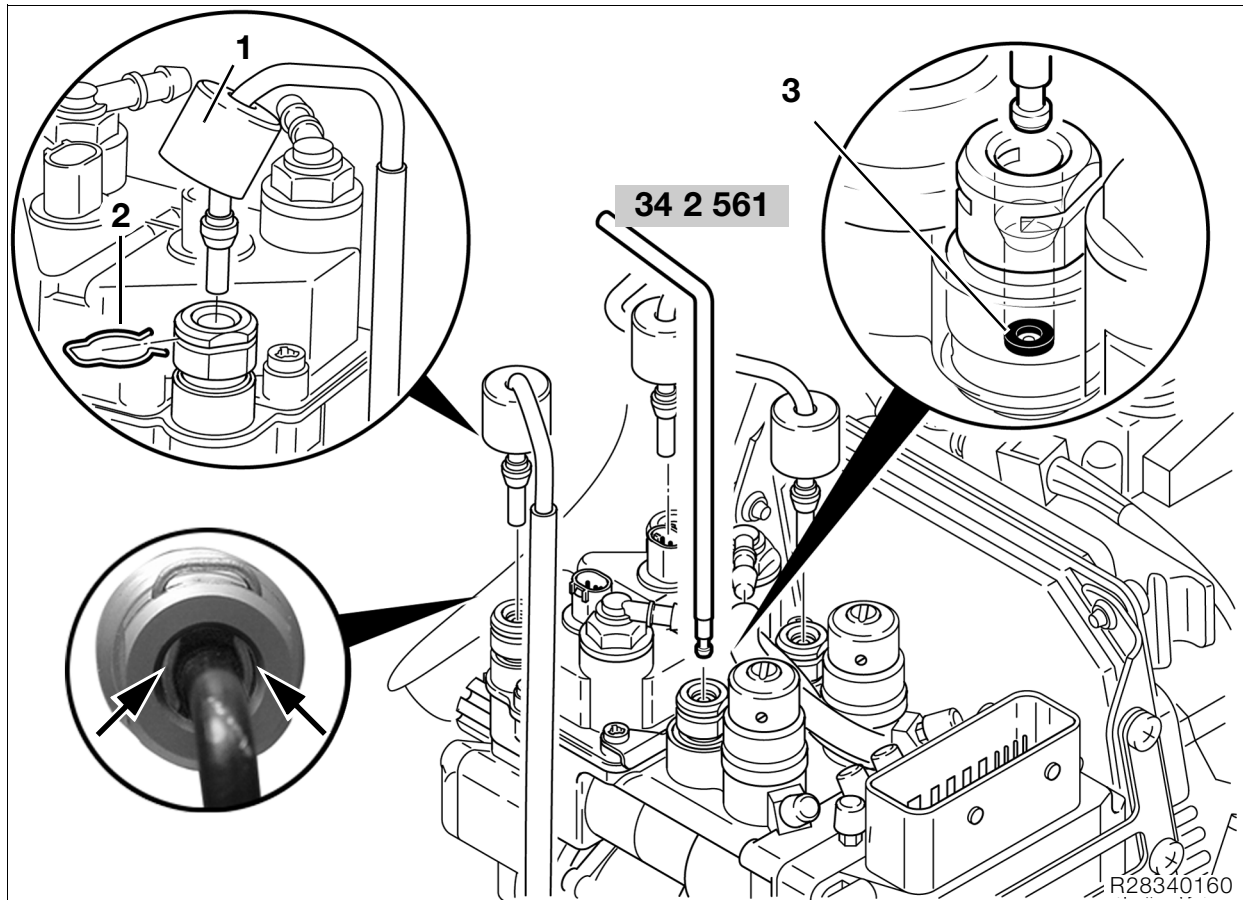

Integral ABS: Removing and installing brake lines

- Drain the brake system (→ 34.16).
- Push protective caps (1) up.
- Remove spring clips (2).
- Remove brake lines.
- Installation is the reverse of the removal procedure: pay particular attention to the following.



Warning:

Always fit new spring clips each time the plugs are disconnected. Ensure correct positioning.



Attention:

Fit new sealing rings for brake line. Secure brake line to master cylinder so that it cannot become kinked or abraded when the handlebars are turned.



Note:

Always replace the seals (square-section rings) between the brake lines and the pressure modulator when you replace the brake lines.

- Carefully remove square-section rings (3) using disassembly tool, **BMW No. 34 2 561**.
- Install square-section rings with brake lines.

- Check that square-section rings are correctly seated.
- Install new spring clips.
- Slip the protective caps up the brake lines.
- Clip in brake lines.
- Check that spring clips are correctly positioned (arrows).
- Seat the protective caps on the connectors.
- Fill and bleed the brake system (→ 34.19).



Tightening torque:

Brake hose and brake line..... 18 Nm
 Bleed screws in front brake calipers..... 7 Nm
 Bleed screw in rear brake caliper 5 Nm

Installed position of front brake line

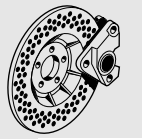

Installed position of rear brake line

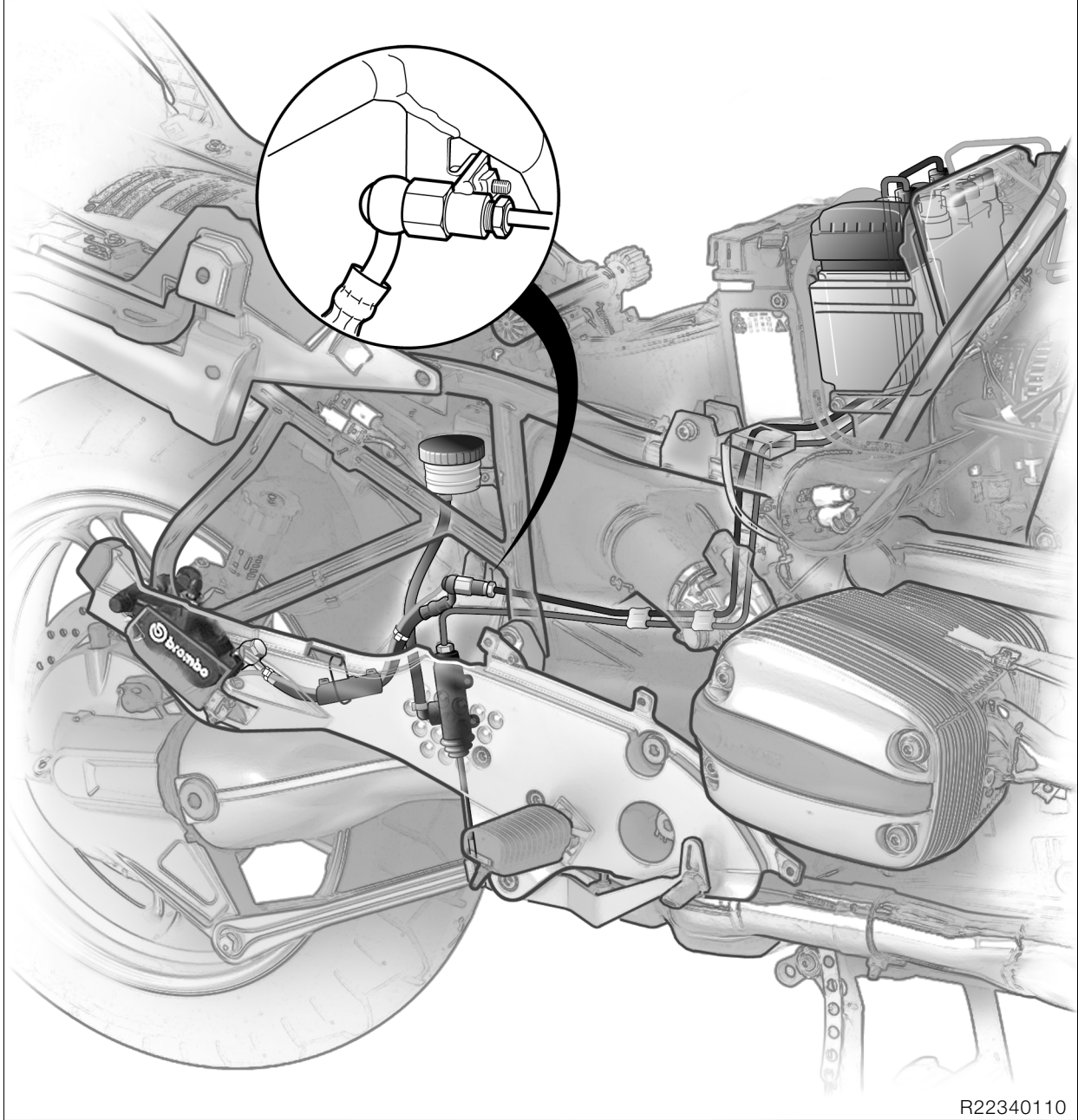

R22340110